



Next Generation Firewall

Models 2201, 2205, 2210

2200 Series

Hardware Guide

Contents

- Introduction on page 2
- Find product documentation on page 2
- Model 2201 features on page 3
- Model 2205 features on page 5
- Model 2210 features on page 7
- Indicator lights on page 8
- Ethernet port indicators on page 8
- SFP+ port indicators on page 8
- SSD indicators on page 8
- Ethernet port names for appliances with interface modules on page 9
- Supported interface modules on page 9
- Precautions on page 19
- Install the appliance on page 21
- Maintenance on page 29

Introduction

Thank you for choosing a Forcepoint appliance.

Familiarize yourself with the appliance ports and indicators and learn how to install the appliance safely.

Find product documentation

In the Forcepoint Customer Hub, you can find information about a released product, including product documentation, technical articles, and more.

You can get additional information and support for your product in the Forcepoint Customer Hub at <https://support.forcepoint.com>. There, you can access product documentation, release notes, Knowledge Base articles, downloads, cases, and contact information.

You might need to log on to access the Forcepoint Customer Hub. If you do not yet have credentials, create a customer account. See <https://support.forcepoint.com/CreateAccount>.

Model 2201 features

The figures and tables show the appliance components and features.

Front panel

This panel has the following parts.

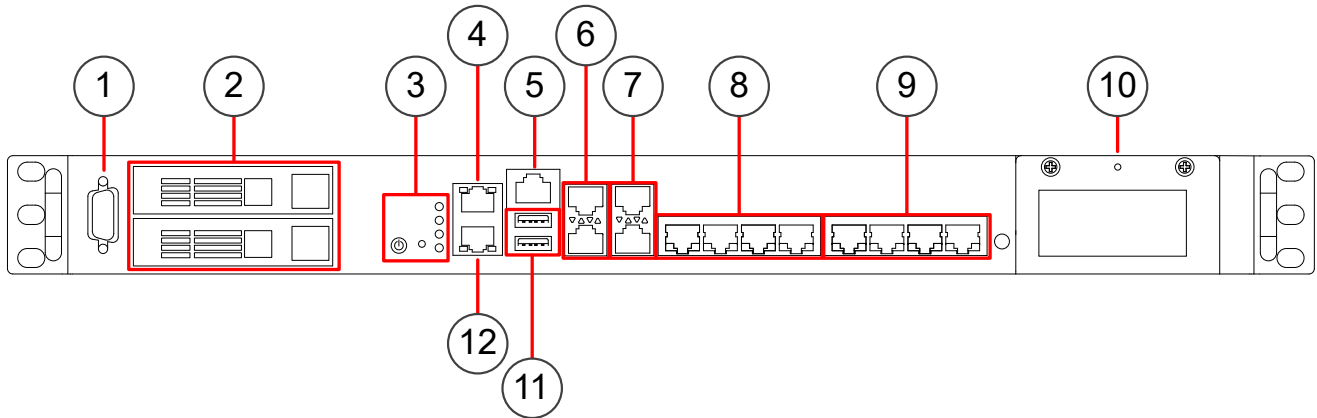

- 1 VGA port
- 2 SSD slots 1-2 from top to bottom
Only SSD 1 is included in the delivery.
- 3 Power button and indicator lights
- 4 Fixed Ethernet port. The port name is eth0_0.
- 5 Console port (speed 115,200 bps)
- 6 Fixed SFP+ ports 1–2
The port names are eth0_1 and eth0_2 from top to bottom.
- 7 Fixed SFP+ ports 3–4
The port names are eth0_3 and eth0_4 from top to bottom.
- 8 Fixed Ethernet ports 5–8
The port names are eth0_5, eth0_6, eth0_7, and eth0_8 from left to right.
- 9 Fixed Ethernet ports 9–12
The port names are eth0_9, eth0_10, eth0_11, and eth0_12 from left to right.
- 10 Interface module slot
- 11 USB ports
- 12 IPMI port (usage not recommended)

Back panel

This panel has the following parts.

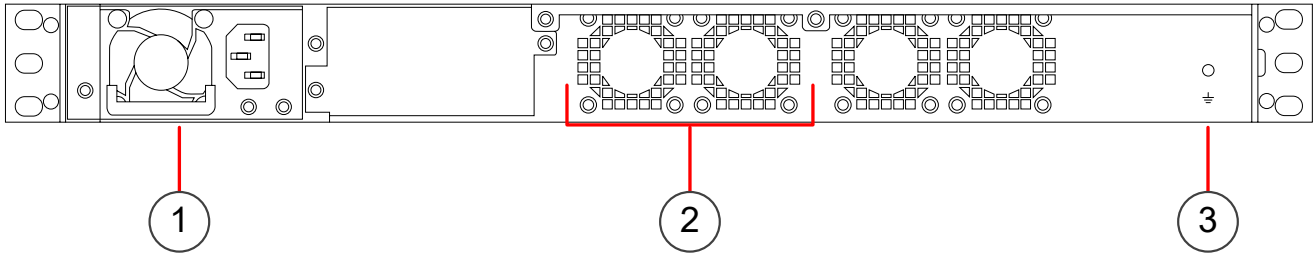

1 Power supply

An AC power supply is included in the delivery. A DC power supply can optionally be purchased separately.

2 Fixed fans 1–2 from left to right

3 Grounding point

Model 2205 features

The figures and tables show the appliance components and features.

Front panel

This panel has the following parts.

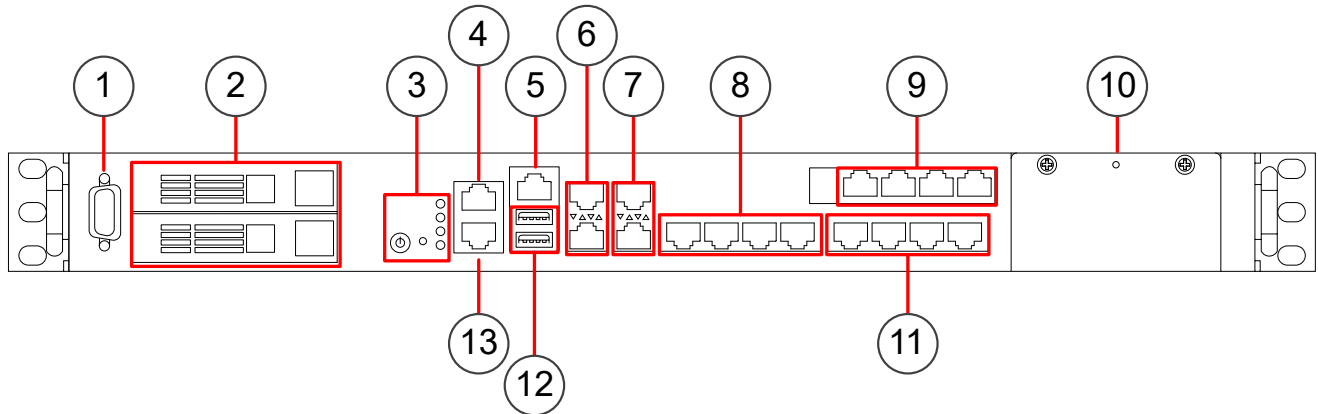

- 1 VGA port
- 2 SSD slots 1-2 from top to bottom
Only SSD 1 is included in the delivery.
- 3 Power button and indicator lights
- 4 Fixed Ethernet port. The port name is eth0_0.
- 5 Console port (speed 115,200 bps)
- 6 Fixed SFP+ ports 1–2
The port names are eth0_1 and eth0_2 from top to bottom.
- 7 Fixed SFP+ ports 3–4
The port names are eth0_3 and eth0_4 from top to bottom.
- 8 Fixed Ethernet ports 5–8
The port names are eth0_5, eth0_6, eth0_7, and eth0_8 from left to right.
- 9 Fixed SFP+ ports 13–16
The port names are eth0_13, eth0_14, eth0_15, and eth0_16 from left to right.
- 10 Interface module slot
- 11 Fixed Ethernet ports 9–12
The port names are eth0_9, eth0_10, eth0_11, and eth0_12 from left to right.
- 12 USB ports
- 13 IPMI port (usage not recommended)

Back panel

This panel has the following parts.

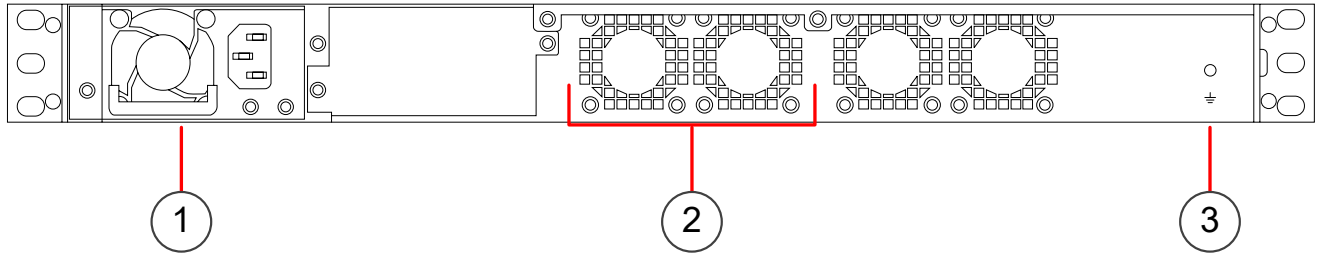

1 Power supply

An AC power supply is included in the delivery. A DC power supply can optionally be purchased separately.

2 Fixed fans 1–2 from left to right

3 Grounding point

Model 2210 features

The figures and tables show the appliance components and features.

Front panel

This panel has the following parts.

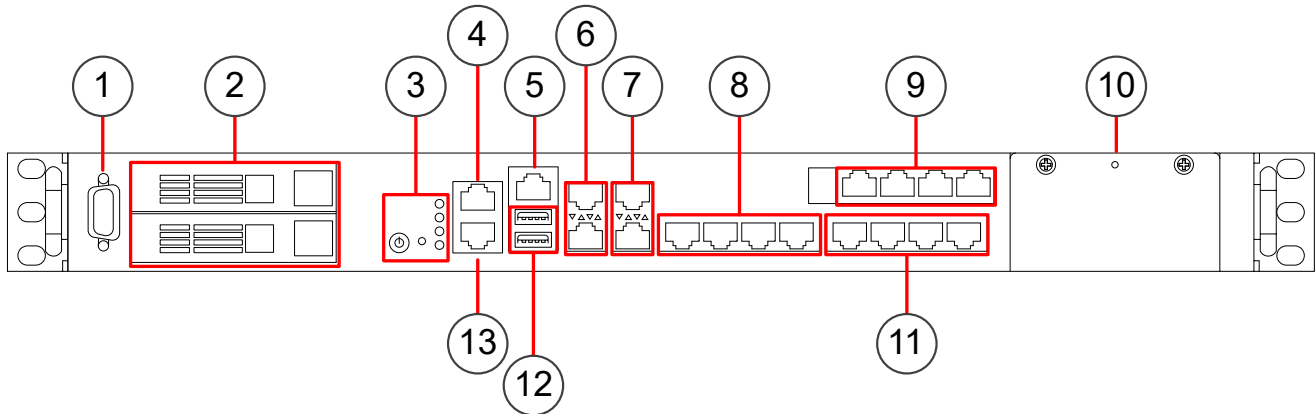

- 1 VGA port
- 2 SSD slots 1-2 from top to bottom
- 3 Power button and indicator lights
- 4 Fixed Ethernet port. The port name is eth0_0.
- 5 Console port (speed 115,200 bps)
- 6 Fixed SFP+ ports 1–2
The port names are eth0_1 and eth0_2 from top to bottom.
- 7 Fixed SFP+ ports 3–4
The port names are eth0_3 and eth0_4 from top to bottom.
- 8 Fixed Ethernet ports 5–8
The port names are eth0_5, eth0_6, eth0_7, and eth0_8 from left to right.
- 9 Fixed SFP+ ports 13–16
The port names are eth0_13, eth0_14, eth0_15, and eth0_16 from left to right.
- 10 Interface module slot
- 11 Fixed Ethernet ports 9–12
The port names are eth0_9, eth0_10, eth0_11, and eth0_12 from left to right.
- 12 USB ports
- 13 IPMI port (usage not recommended)

Back panel

This panel has the following parts.

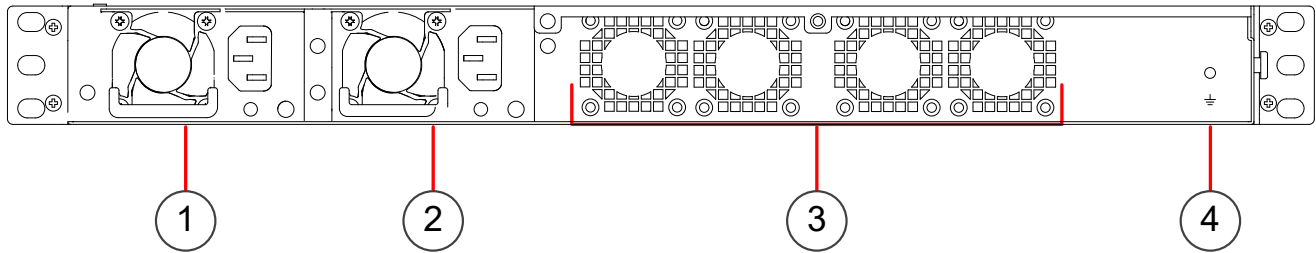

1 Power supply 1

An AC power supply is included in the delivery. A DC power supply can optionally be purchased separately.

2 Power supply 2

An AC power supply is included in the delivery. A DC power supply can optionally be purchased separately.

3 Fixed fans 1–4 from left to right

4 Grounding point

Indicator lights

Indicator lights show the status of the appliance and any fixed Ethernet ports.

Ethernet port indicators

Ethernet port indicators show the status and speed of the network ports.

SFP+ port indicators

SFP+ port indicators show the status and speed of the network ports.

SSD indicators

SSD indicators show the status of the SSDs.

Ethernet port names for appliances with interface modules

Ethernet port names are based on the slot and port numbers.

The first number in the name represents the slot on the appliance. The second number represents the port on the slot. For example, eth2_0 is located on port 0 of slot 2.

Supported interface modules

Forcepoint NGFW appliances support the following types of interface modules. For a list of all available interface modules and compatibility information, see Knowledge Base article [10245](#).



Note

Do not remove any stickers from modules — they contain important information.

Copper modules

Module	Identifier	Appliance models
8 port gigabit Ethernet RJ45	MODG8	2201, 2205, 2210
8 port gigabit Ethernet RJ45 copper bypass module	MODG8B	2201, 2205, 2210

Fiber modules

Module	Identifier	Appliance models
4 port 10 gigabit Ethernet long reach bypass LC module	MOD10L4B	2201, 2205, 2210
4 port 10 gigabit Ethernet short reach bypass LC module	MOD10S4B	2201, 2205, 2210
2 Port 40 gigabit Ethernet bypass MPO module	MOD40F2B	2201, 2205, 2210

SFP modules

Module	Identifier	Appliance models
2 port 25 gigabit Ethernet SFP+	MOD25F2	2201, 2205, 2210
2 port 40 gigabit Ethernet QSFP	MOD40F2	2201, 2205, 2210
4 port 10 gigabit Ethernet SFP+	MOD10F4	2201, 2205, 2210
8 port gigabit Ethernet SFP	MODGF8	2201, 2205, 2210
8 port 10 gigabit Ethernet SFP+	MOD10F8	2201, 2205, 2210

MODG8 module

The MODG8 module is an 8 port gigabit Ethernet RJ45 module.

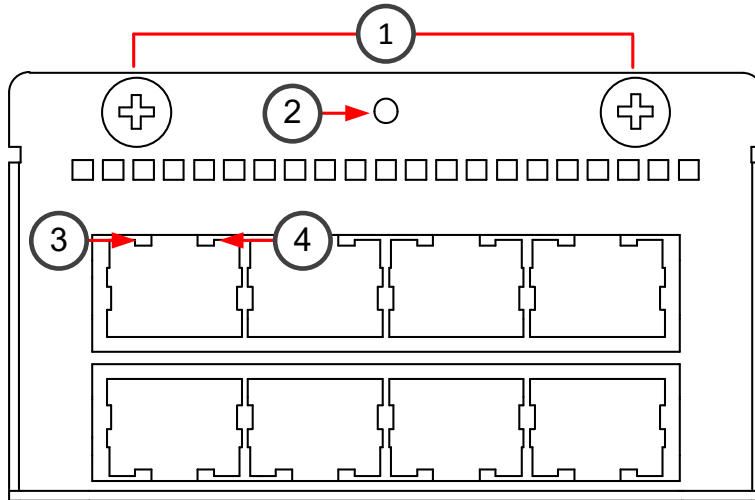

- 1 Thumbscrews**
You must unfasten the thumbscrews to replace or remove the module.
- 2 Fastening screw**
You must remove this screw to replace or remove the module.
- 3 Activity/link indicators**
When green, the link is OK. Flashes on activity.
- 4 Link speed indicators**
When green, the speed is 1 Gbps.
When amber, the speed is 100 Mbps.

MODG8B module

The MODG8B module is an 8 port gigabit Ethernet copper bypass module.

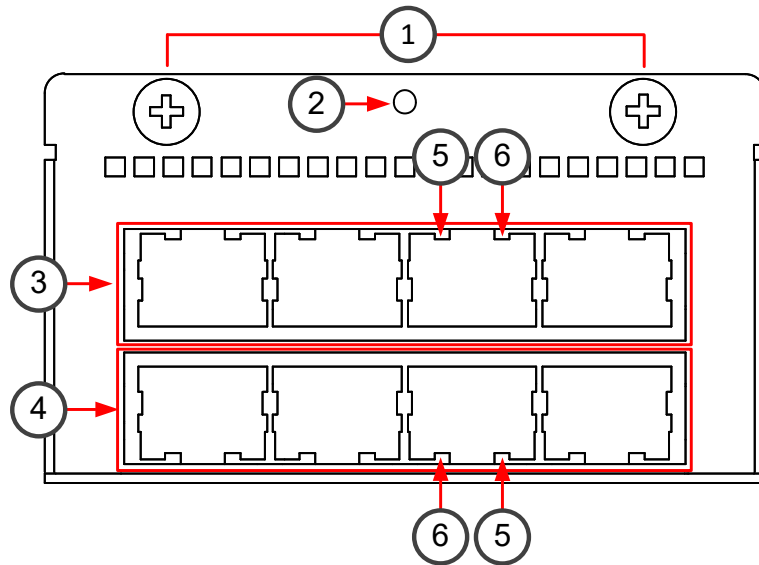

1 Thumbscrews

You must unfasten the thumbscrews to replace or remove the module.

2 Fastening screw

You must remove this screw to replace or remove the module.

3 Ethernet ports 4–7 from left to right

The Ethernet ports are used in the following even-odd pairs for bypass:

- 4–5
- 6–7

4 Ethernet ports 0–3 from left to right

The Ethernet ports are used in the following even-odd pairs for bypass:

- 0–1
- 2–3

5 Activity/link indicators

When green, the link is OK. Flashes on activity.

When amber, bypass mode is active.

6 Link speed indicators

When green, the speed is 1 Gbps.

When amber, the speed is 100 Mbps.

MOD10L4B module

The MOD10L4B module is a 4 port 10 gigabit Ethernet long reach bypass module.

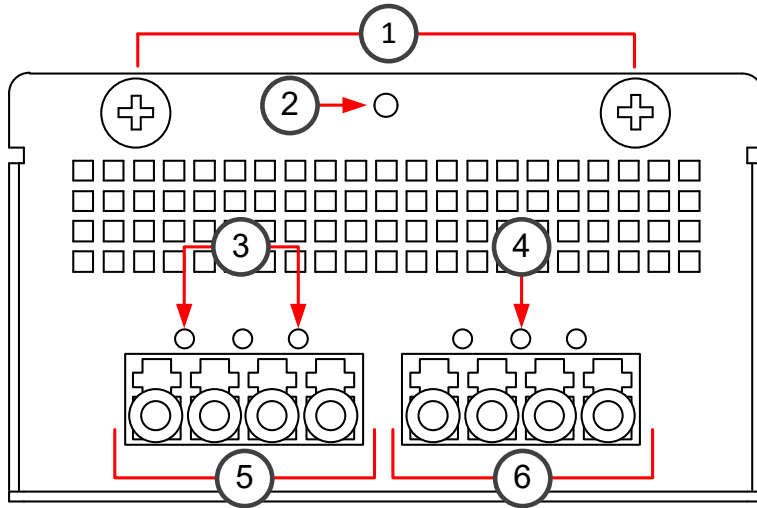

- 1** Thumbscrews
You must unfasten the thumbscrews to replace or remove the module.
- 2** Fastening screw
You must remove this screw to replace or remove the module.
- 3** Activity/link indicators
When green, the link is OK. Flashes on activity.
- 4** Bypass indicator
When amber, bypass mode is active.
- 5** Ethernet ports 0–1 from left to right
- 6** Ethernet ports 2–3 from left to right

The Ethernet ports are used in the following even-odd pairs for bypass:

- 0–1
- 2–3

MOD10S4B module

The MOD10L4B module is a 4 port 10 gigabit Ethernet short reach bypass module.

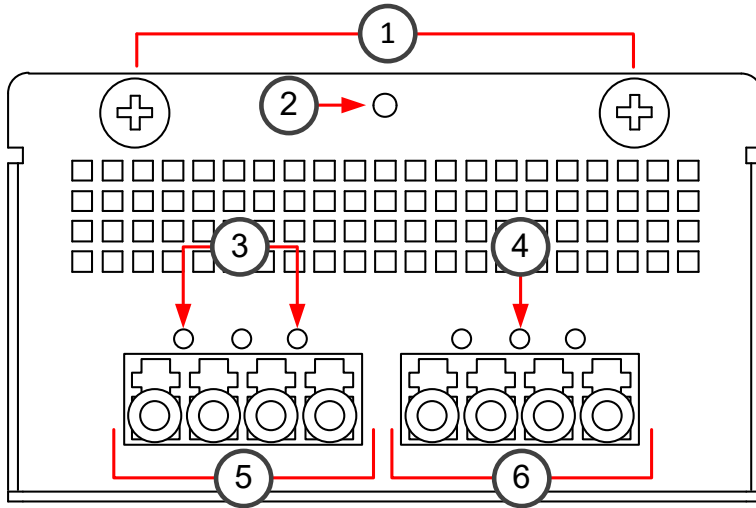

- 1** Thumbscrews
You must unfasten the thumbscrews to replace or remove the module.
- 2** Fastening screw
You must remove this screw to replace or remove the module.
- 3** Activity/link indicators
When green, the link is OK. Flashes on activity.
- 4** Bypass indicator
When amber, bypass mode is active.
- 5** Ethernet ports 0–1 from left to right
- 6** Ethernet ports 2–3 from left to right

The Ethernet ports are used in the following even-odd pairs for bypass:

- 0–1
- 2–3

MOD40F2B module

The MOD40F2B module is a 2 Port 40 gigabit Ethernet QSFP+ bypass module.

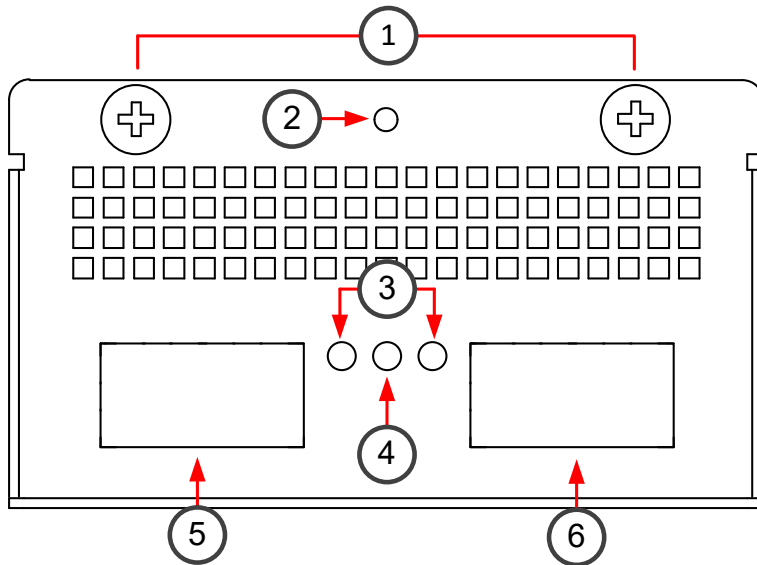

- 1** Thumbscrews
You must unfasten the thumbscrews to replace or remove the module.
- 2** Fastening screw
You must remove this screw to replace or remove the module.
- 3** Activity/link indicators
When green, the link is OK. Flashes on activity.
- 4** Bypass indicator
When amber, bypass mode is active.
- 5** Ethernet port 0
- 6** Ethernet port 1

The Ethernet ports are used in the following even-odd pair for bypass:

- 0-1

MOD25F2 module

The MOD25F2 module is a 2 port 25 gigabit Ethernet SFP+ module.

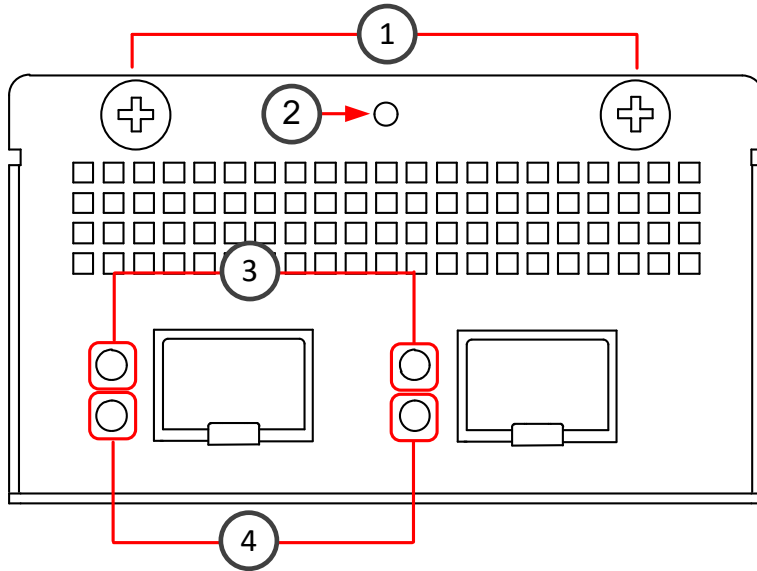

1 Thumbscrews

You must unfasten the thumbscrews to replace or remove the module.

2 Fastening screw

You must remove this screw to replace or remove the module.

3 Activity/link indicators

The indicators are labeled with the port that is represented.

When green, the link is OK. Flashes on activity.

4 Link speed indicators

When green, the speed is 25 Gbps.

MOD40F2 module

The MOD40F2 module is a 2 port 40 gigabit Ethernet QSFP module.

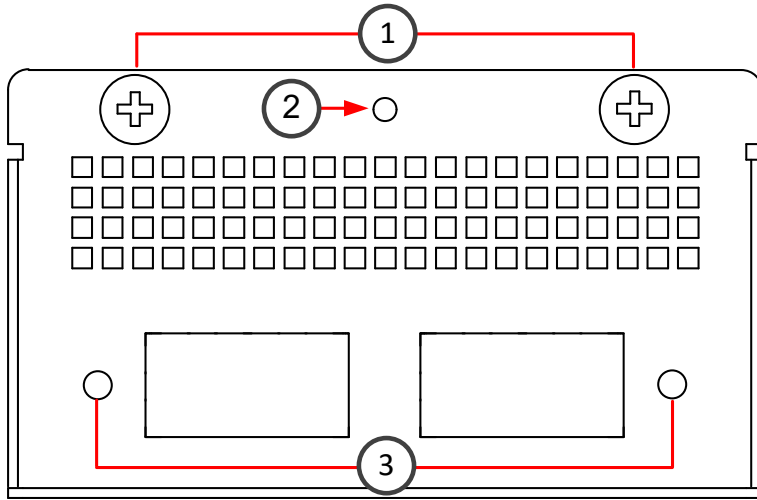

1 Thumbscrews

You must unfasten the thumbscrews to replace or remove the module.

2 Fastening screw

You must remove this screw to replace or remove the module.

3 Activity/link indicators

The indicators are labeled with the port that is represented.

When green, the link is OK. Flashes on activity.

MOD10F4 module

The MOD10F4 module is a 4 port 10 gigabit Ethernet SFP+ module.

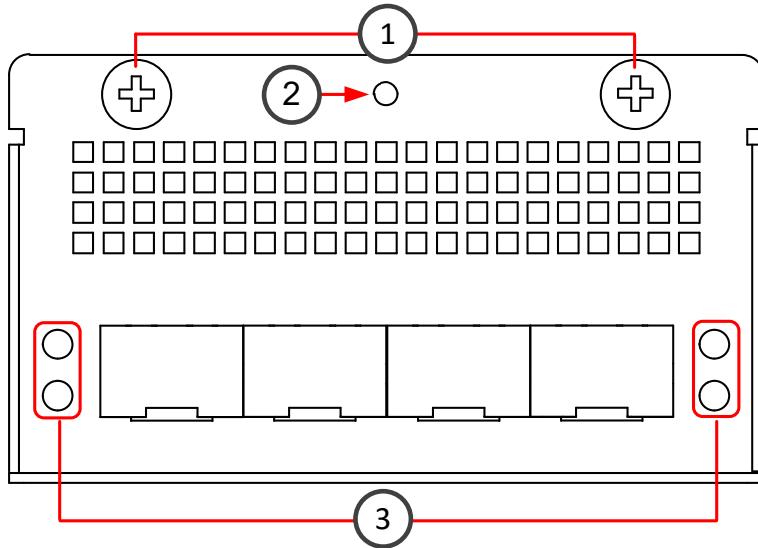

1 Thumbscrews

You must unfasten the thumbscrews to replace or remove the module.

2 Fastening screw

You must remove this screw to replace or remove the module.

3 Activity/link indicators

The indicators are labeled with the port that is represented.

When green, the link is OK. Flashes on activity.

MODGF8 module

The MODGF8 module is an 8 port gigabit Ethernet SFP module.

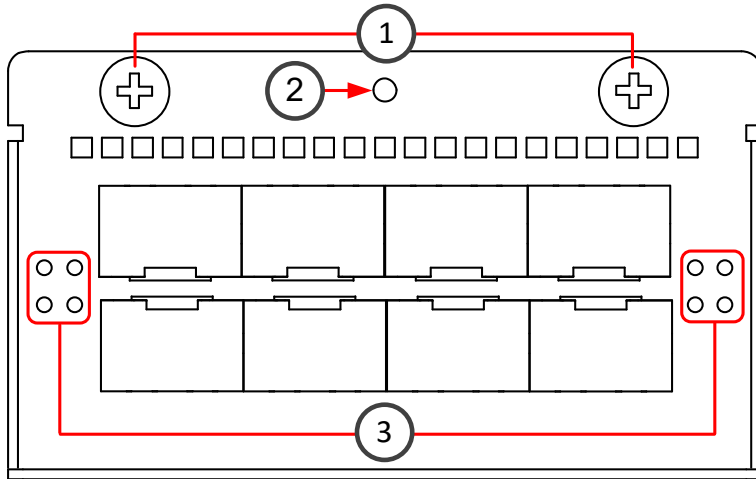

1 Thumbscrews

You must unfasten the thumbscrews to replace or remove the module.

2 Fastening screw

You must remove this screw to replace or remove the module.

3 Activity/link indicators

The indicators are labeled with the port that is represented.

When green, the link is OK. Flashes on activity.

MOD10F8 module

The MOD10F8 module is an 8 port 10 gigabit Ethernet SFP+ module.

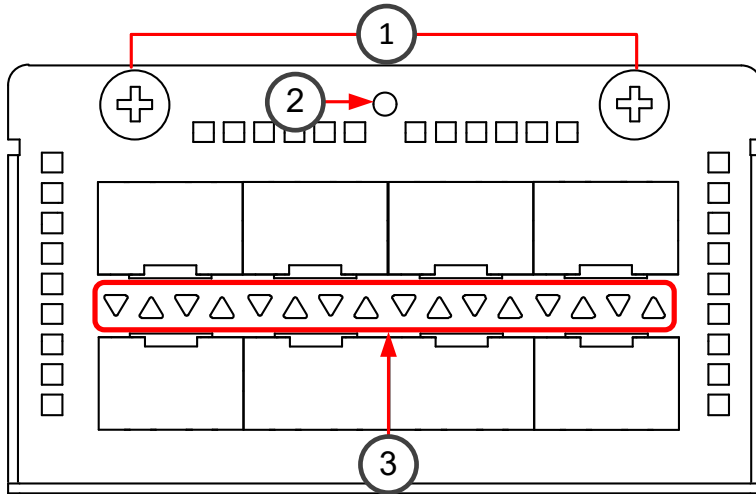

1 Thumbscrews

You must unfasten the thumbscrews to replace or remove the module.

2 Fastening screw

You must remove this screw to replace or remove the module.

3 Link status and speed indicators

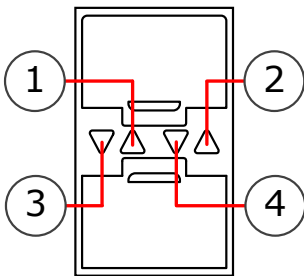

- 1** Link speed indicator for the upper port
When green, the link speed is 10 Gbps.
- 2** Link status indicator for the upper port
When blue, the link is OK.
- 3** Link speed indicator for the lower port
When green, the link speed is 10 Gbps.
- 4** Link status indicator for the lower port
When blue, the link is OK.

Precautions

The precautions provide safety guidance when working with Forcepoint appliances and electrical equipment. For additional safety information, see the *Forcepoint Product Safety and Regulatory Compliance Guide*.

General safety precautions

Read the safety information and follow these rules to ensure general safety whenever you are working with electronic equipment.

- Keep the area around the appliance clean and free of clutter.
- Use a regulating uninterruptible power supply (UPS) to keep your system operating during power failures and to protect the appliance from power surges and voltage spikes.
- If you need to turn off or unplug the appliance, always wait at least five seconds before turning on or plugging in the appliance again.

Operating precautions

Follow these precautions when operating the appliance.

Electrical safety precautions

Follow basic electrical safety precautions to protect yourself from harm and the appliance from damage.

- Know the locations of the power on/off button and the emergency turn-off switch, disconnection switch, or electrical outlet for the room. If an electrical accident occurs, you can quickly turn off power to the system.
- When working with high-voltage components, do not work alone.
- When working with electrical equipment that is turned on, use only one hand. This is to avoid making a complete circuit, which causes an electric shock. Use extreme caution when using metal tools, which can easily damage any electrical components or circuit boards the tools come into contact with.
- Do not use mats designed to decrease electrostatic discharge as protection from electric shock. Instead, use rubber mats that have been designed as electrical insulators.
- If the power supply cable includes a grounding plug, the plug must be plugged into a grounded electrical outlet.
- Use only the power cable or cables supplied with the appliance.

AC power supply safety precautions

The appliance power inlet is the disconnect device on the appliance.

DC power supply safety precautions

Follow these precautions for DC power supplies.

- The appliance must be used in a restricted access location and users must be well trained to operate it.
- The outlet for the appliance must be installed near the appliance and be easily accessible.
- The appliance must be protected against electric shock.
- The mains supply plug on the power supply cable is the disconnect device on the appliance. To disconnect the appliance, you must first disconnect the mains, then disconnect the ground.

Install the appliance

There are several tasks that must be completed before the appliance is installed.

These tasks and the installation of the appliance might be done by the same person or by different persons:

- The Security Management Center (SMC) administrator is responsible for the tasks that are needed before the appliance is installed.
- The on-site installer is responsible for installing the appliance.

For more information, see the *Forcepoint Next Generation Firewall Installation Guide*.

To prepare for the appliance installation, the SMC administrator must do the following:

- 1) If the SMC has not yet been installed, install the SMC.



Important

Do not install the SMC on the NGFW appliance.

The SMC can manage many NGFW appliances.

- 2) In the Management Client component of the SMC, create and configure the NGFW Engine element that represents the appliance.
- 3) In the Management Client component of the SMC, save the initial configuration.
The SMC administrator must either:
 - Upload the initial configuration to the Installation Server for plug-and-play configuration of the appliance.



Note

There are additional requirements for plug-and play configuration. See Knowledge Base article [9662](#).

- Give the on-site installer a USB drive that contains an initial configuration file for each appliance.

The on-site installer must do the following:

- 1) Inspect the appliance, delivery box, and all components included in the shipment.



Important

Do not use damaged appliances or components.

- 2) Connect all necessary power and network cables and other components, then turn on the appliance.
If the plug-and-play configuration method is not used, the on-site installer must use the USB drive that contains the initial configuration files to configure the NGFW Engine software.
- 3) When you have finished installing the appliance, inform the SMC administrator so that the administrator can check the status of the appliance in the Management Client.

Rack-mount the appliance

The rack-mounting procedure varies depending on the type of rack unit. If needed, see the documentation for your rack unit.

Determine the placement of each component in the rack.

- Install the heaviest components on the bottom of the rack first. Install components from the bottom to the top.
- The appliance must be connected to a grounded power outlet.
- Use a UPS to protect the appliance from power surges and voltage spikes, and to keep your system operating if there is a power failure.
- To maintain proper cooling, always keep the front door of the rack and all panels and components on the appliances closed when not servicing.

Install the 2200 Series appliance in a 4 post rack using fixed brackets

Use the rack-mounting brackets to secure the appliance in the rack.

Steps

- 1) Locate the brackets for the rack installation.
- 2) Attach a long bracket to each of the back posts of the rack.
- 3) Attach three screws to each side of the appliance.

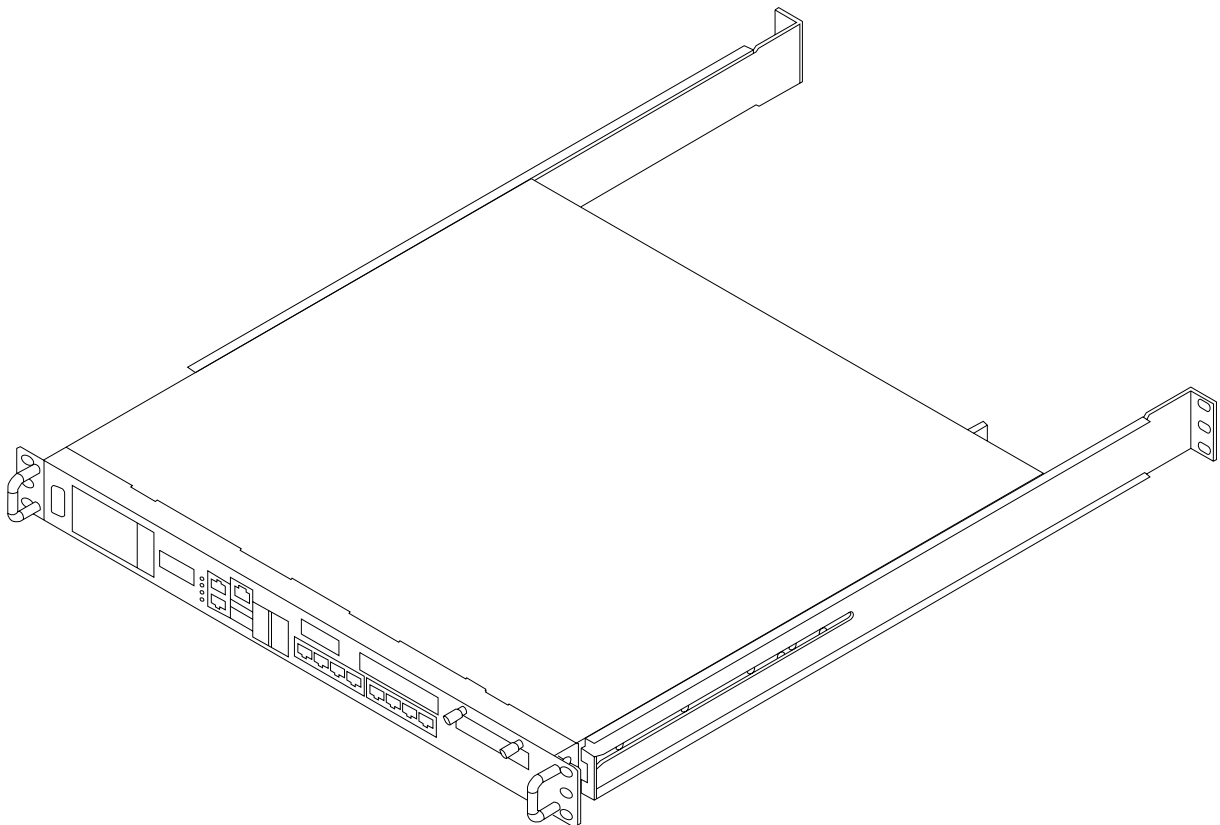

- 4) Lift the appliance into the rack, and guide the screws in the side of the appliance into the groove of the bracket.

The bracket is used to support the appliance when setting the depth of the appliance in the rack.

- 5) Attach the front panel to the front posts of the rack with three screws in each post.

Install the 2200 Series appliance in a 4 post rack using sliding brackets

Use separately purchased sliding brackets to install the appliance in a 4 post rack.



Note

The sliding brackets are not included in the appliance delivery.

Steps

- 1) Locate the brackets for the rack installation.
- 2) Remove the handle brackets attached to each side of the front of the appliance.
- 3) Detach the inner rails from the outer rails. Press down the locking tab to pull out the inner rail.

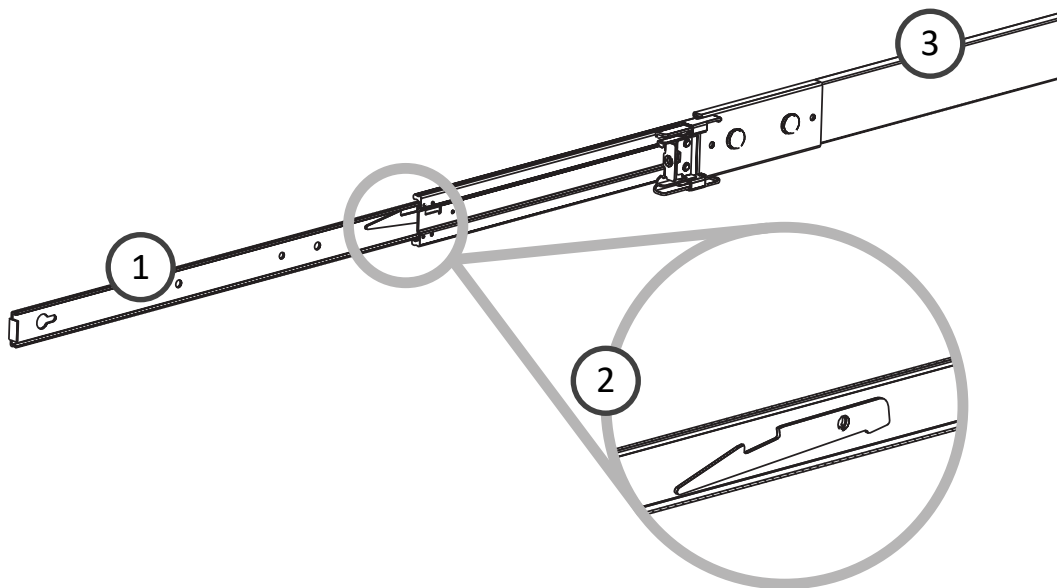

- 1 Inner rail
- 2 Locking tab
- 3 Outer rail

- 4) Attach an inner rail to each side of the appliance using three screws for each rail.
 - The inner rails are marked with "LH" for left and "RH" for right.
 - The outer rails are marked with "Front" for the front end and "Rear" for the rear end.
 - When looking at the appliance from the front, the outer rail that was attached to the inner rail marked "LH" must be attached to the left side of the rack, and the outer rail that was attached to the inner rail marked "RH" must be attached to the right side of the rack.

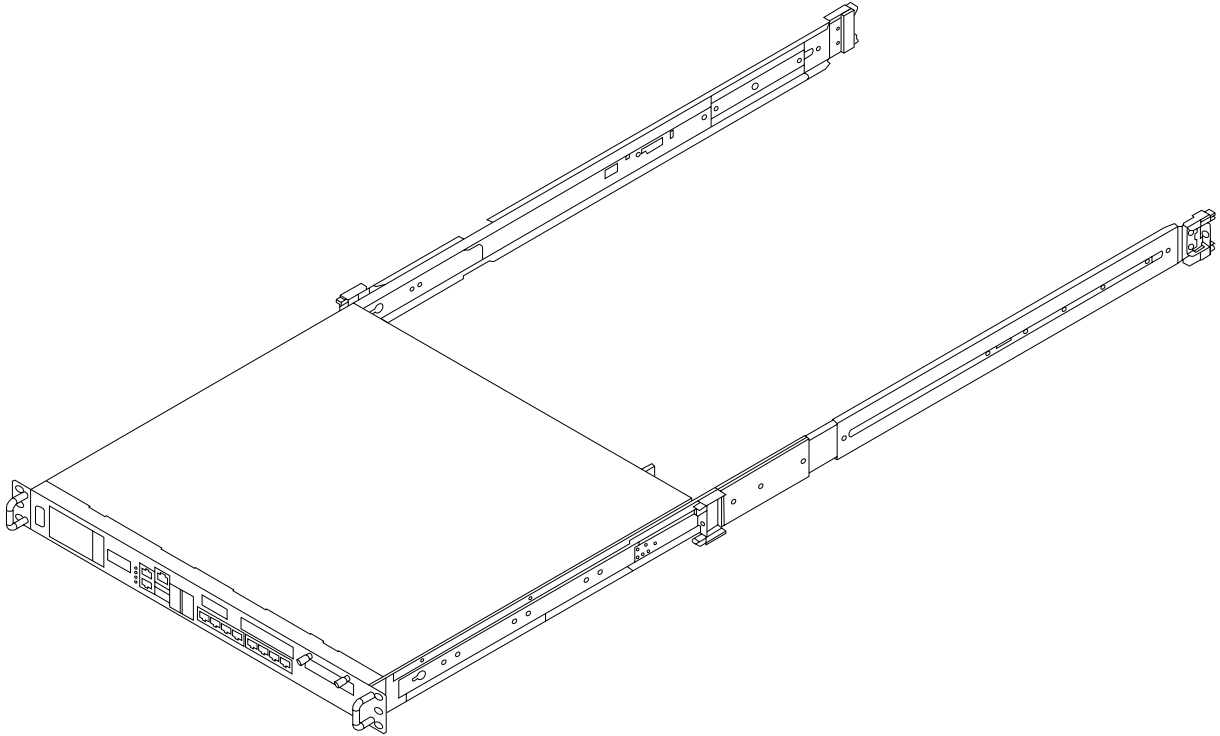

- 5) Slide the outer rail onto the inner rail.
- 6) Release the safety lock on the front end of the outer rail by pulling it back.

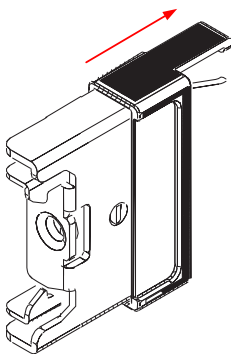

- 7) Insert the outer rail into the rack.

If the ends of the outer rails do not fit into the holes in the rack, use the adapter brackets included in the delivery.

- 8) Push the safety lock forward to secure the rail into the rack.

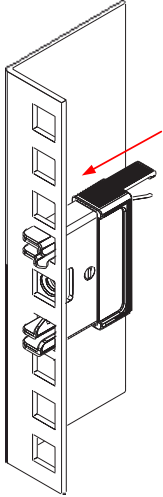

- 9) Insert the other outer rail into the rack.
- 10) Line up the rear of the inner rails with the front of the outer rails.
- 11) Slide the inner rails into the outer rails, keeping the pressure even on both sides. You might have to press the locking tabs when inserting.
The rails lock into the rack when the appliance is pushed completely into the rack.

Install the 2200 Series appliance in a 2 post rack

Use the rack-mounting brackets to secure the appliance in the rack.

Steps

- 1) Locate the brackets for the rack installation.

- 2) Attach a short bracket to each side of the appliance with five screws.

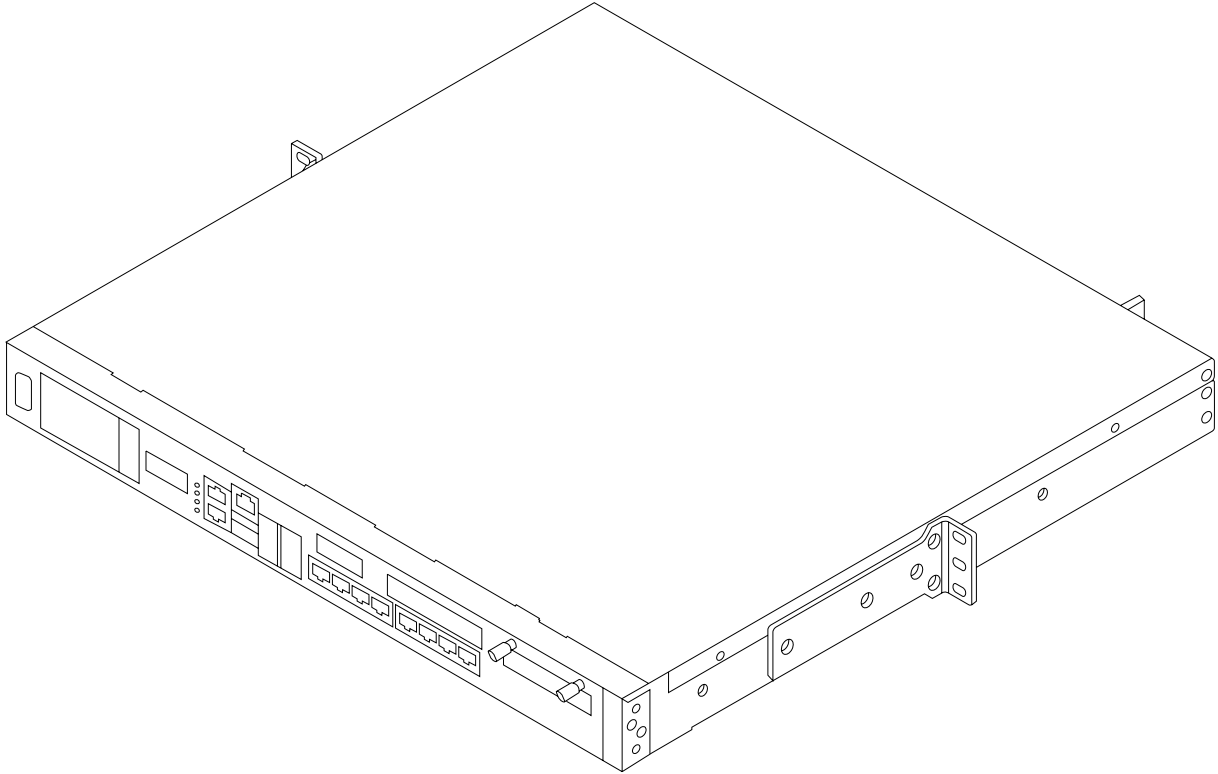

- 3) Attach the brackets to the rack with three screws through the holes in the front of the brackets.

Install an interface module

If you have interface modules, install them in the appliance.

Before you begin

Read the safety precautions and make sure any interface modules you install are the correct type for your appliance.



CAUTION

To avoid damaging the modules or the appliance, do not install or remove any interface modules if the appliance is turned on.



Note

We recommend fastening a grounding strap to your wrist so that it contacts your bare skin and attaching the other end of the strap to the appliance.

Steps

- 1) Locate the slot to install the module in.

- 2) Push the module into the slot.

**Note**

If the module has a sticker, make sure that the sticker faces up.

**Important**

Do not insert the module in the wrong orientation. Inserting the modules incorrectly might damage the appliance and the modules and voids the warranty.

Connect the cables

Connect the network and power cables.

Use at least CAT5e-rated cables for gigabit networks.

Network interfaces at both ends of each cable must have identical speed and duplex settings. These settings include the automatic negotiation setting. If one end of the cable uses autonegotiation, the other end must also use autonegotiation. Gigabit standards require interfaces to use autonegotiation. Fixed settings are not allowed at gigabit speeds.

Ethernet port mapping

For appliances that have removable interface modules, Ethernet port names are based on the slot and port numbers.

The first number in the name represents the slot on the appliance, and the second number represents the port on the slot. For example, eth2_0 is located on port 0 of slot 2.

- Slot 0 is used for the fixed Ethernet ports.
- Slots 1 and higher are used for the ports on the interface modules.
The port numbers start at 0 and increase from left to right.

During the initial configuration of the appliance, you map the Ethernet ports to the interface IDs that you defined in the Management Client.

The NGFW Configuration Wizard shows the mapping between the interface IDs and port names. In the command line version of the NGFW Configuration Wizard, Interface IDs appear in the **ID** column and port names appear in the **Name** column.

This mapping can change if you replace an interface module. If the new module has more Ethernet ports, the interface IDs for the new ports start from the next free interface ID number.

Example: You have thirteen interfaces numbered 0–12, which includes a four-port module installed in slot 1. If you replace the four-port module installed in slot 1 with a two-port module, eth1_2 with ID 10 and eth1_3 with ID 11 are removed.

Example before and after ID mapping

ID	Name	Driver
	modem0	
0	eth0_0	igb
1	eth0_1	igb
2	eth0_2	igb
3	eth0_3	igb
4	eth0_4	ixgbe
5	eth0_5	ixgbe
6	eth0_6	ixgbe
7	eth0_7	ixgbe
8	eth1_0	igb
9	eth1_1	igb
10	eth1_2	igb
11	eth1_3	igb
12	wlan0	ath10k_pci
	<Add..>	<Autod



ID	Name	Driver
	modem0	
0	eth0_0	igb
1	eth0_1	igb
2	eth0_2	igb
3	eth0_3	igb
4	eth0_4	ixgbe
5	eth0_5	ixgbe
6	eth0_6	ixgbe
7	eth0_7	ixgbe
8	eth1_0	igb
9	eth1_1	igb
12	wlan0	ath10k_pci
	<Add..>	<Add..>

Connect network and management cables

Connect the appliance to your networks. The management connection allows you to view the system console.



Note

Ethernet ports are mapped to interface IDs during the initial configuration. The ports and port numbers of the physical appliance must match the interface definitions and interface IDs configured for the engine in the Management Client.

Steps

- 1) Determine which Ethernet ports to use and connect the ports to your networks.
- 2) Select one of these options for the management connection depending on the appliance model and features:
 - Connect a null-modem cable to the console port of the appliance and to another computer for a terminal connection.
 - Connect a monitor to the VGA port and a keyboard to a USB port.

Connect network cables

Ethernet ports are mapped to interface IDs during the initial configuration. Determine which Ethernet ports to use for connecting to your networks.

Steps

- 1) Connect network cables to the Ethernet ports.

Connect network cables to SFP ports

If you installed an SFP interface module on the appliance or the appliance has an integrated SFP port, insert the copper or fiber-optic SFP transceiver into the port, then connect the cables.

Steps

- 1) Insert the SFP transceiver in the port slot until you feel the connector on the transceiver snap into place.



Note

Make sure that the latch on the SFP transceiver is up when you insert the SFP transceiver in the port slot.

- 2) If the SFP transceiver has a rubber plug, remove the plug.
- 3) Connect the copper or fiber-optic cable to the SFP transceiver.



Note

Each SFP port must match the wavelength specifications at the other end of the cable. The cable must not exceed the stipulated cable length for reliable communications.

Connect the power supplies

Connect power cables to the power supplies on the back of the appliance.

Before you begin

See the safety precautions topic for information about power supplies.

We highly recommend the following configurations.

- On appliances that have two power supply modules for redundant power sources, connect both power supplies to a power source. Connecting both power supplies ensures that the appliance can function if one of the power supplies fails.
- Use a UPS to ensure continuous operation and minimize the risk of damage to the appliance in case of sudden loss of power. For a truly redundant power supply, connect each power connector on the appliance to a different UPS, so that the failure of one UPS does not cut power to both power supplies.



Note

Standby power is supplied to the system even when the appliance is turned off.

Steps

- 1) Connect the power cables to the power connectors on the back of the appliance.
- 2) Plug the power cable into a grounded, high-quality power strip that offers protection from electrical noise and power surges.

Maintenance

Turn off the appliance

Most Forcepoint NGFW appliance hardware components are not hot-swappable. Turn off the appliance from the NGFW Engine command line.



Tip

The SMC administrator can also turn off the appliance remotely using the Management Client. For more information, see the *Forcepoint Next Generation Firewall Product Guide*.

Steps

- 1) Connect to the NGFW Engine command line.

Depending on the appliance type, use one of the following options:

- Connect a computer running a terminal emulator program to the appliance console port, then press **Enter**.
- Connect using SSH.



Note

SSH access is not enabled by default.

- Connect a keyboard to a USB port and a monitor to the VGA port, then press **Enter**.

- 2) Enter the logon credentials.

The user name is `root` and the password is the one you set for the appliance.

- 3) Enter the following command:

```
halt
```

- 4) Wait until the power indicator light turns red or is unlit, then unplug all power cables from the appliance.

Replace the power supply

The power supplies are replaceable on most Forcepoint NGFW appliances.



CAUTION

Do not open the casing of a power supply module. Power supply modules can only be repaired by a qualified technician from the manufacturer.



Note

We recommend fastening a grounding strap to your wrist so that it contacts your bare skin and attaching the other end of the strap to the appliance.

Steps

- 1) Disconnect the power cable from the power supply module.

- 2) Pull out the power supply module using the handle provided.
- 3) Push the replacement power supply module into the power slot until it clicks in place.

Replace the SSD

Replace an SSD with another of the same model.



Note

We recommend fastening a grounding strap to your wrist so that it contacts your bare skin and attaching the other end of the strap to the appliance.



CAUTION

Uninstalled SSDs are sensitive to damage from electrostatic discharge.

Steps

- 1) Turn off the appliance and disconnect any power cables.
- 2) Remove the SSD from the tray, then insert the new SSD into the tray.
- 3) Insert the SSD into the same slot as the SSD that you removed.

Replace an interface module

Replace an interface module with the same type or a different type of module.



Note

We recommend fastening a grounding strap to your wrist so that it contacts your bare skin and attaching the other end of the strap to the appliance.

Steps

- 1) Turn off the appliance and disconnect any power cables.
- 2) Insert the new module.
- 3) Connect the cables and plug the power cables to the system and to the wall outlets.

- 4) Turn on the appliance.



CAUTION

To ensure proper cooling, do not turn on the appliance if you have not installed an interface module or a placeholder module in each slot.

- 5) Update the interface configuration.

- a) On the command line of the NGFW Engine, enter the following command to start the NGFW Configuration Wizard:

```
sg-reconfigure
```

- b) In the network interface configuration options, make sure that the autodetected information is correct and that all interfaces have been detected.
If autodetection fails, add network drivers manually. For detailed instructions, see the *Forcepoint Next Generation Firewall Installation Guide*.
- c) If the number of ports in the new module differs from the old module, adjust the mapping of interfaces to interface IDs.



CAUTION

Do not select the **Clear** action when modifying interface IDs in the NGFW Configuration Wizard on the command line. Selecting **Clear** removes all mapping information between interface IDs and Ethernet ports, and restores the default values.

- d) On the **Prepare for Management Contact** page, highlight **Finish**, then press **Enter**.
- e) If the number of ports in the new module differs from the old module, modify the interface definitions in the Management Client, then refresh the policy to transfer the interface changes to the engine.
Make sure to use the same interface IDs that you mapped to the interfaces in the NGFW Configuration Wizard for the interface definitions in the Management Client.

Reattach the cover plate to the interface module slot

Reattach the module cover plate if there is no module in the slot.



CAUTION

Do not turn on the appliance if a slot is empty or uncovered. Using the appliance without an interface module or the cover plate can damage the appliance and voids the warranty.



Note

We recommend fastening a grounding strap to your wrist so that it contacts your bare skin and attaching the other end of the strap to the appliance.

Steps

- 1) Turn off the appliance.
- 2) Remove the interface module from the interface module slot.
- 3) Locate the tab at the lower left corner of the plate.
- 4) Insert the tab into the hole in the lower left corner of the slot casing.

