



FORCEPOINT

Stonesoft Next Generation Firewall

Hardware Guide

**Models 321, 325, 1035, 1065, 1401,
1402**

Revision E

Table of contents

- 1 Appliance features..... 3**
 - Model 321 features..... 3
 - Model 325 features..... 4
 - Model 1035 and 1065 features..... 6
 - Model 1401 and 1402 features..... 8
 - Interface modules..... 9

- 2 Precautions..... 16**
 - Safety precautions..... 16
 - Electrical safety precautions..... 16
 - Power supply safety precautions..... 16

- 3 Install the appliance..... 18**
 - Install an interface module..... 18
 - Rack-mount the appliance..... 19
 - Connect the cables..... 26

- 4 Maintenance..... 31**
 - Turn off the appliance..... 31
 - Replace the power supply..... 31
 - Replace the appliance fans..... 32
 - Replace the CFast card..... 32
 - Replace an interface module..... 32
 - Remove SFP transceivers..... 33
 - Reattach the cover plate to the interface module slot..... 33

- 5 Compliance information..... 35**
 - Applied technologies..... 35
 - National restrictions and requirements for authorization..... 35

- 6 Find product documentation..... 36**

Appliance features

Familiarize yourself with the front panel, back panel, and indicator lights.

Model 321 features

The figures and tables show the appliance components.

Front panel

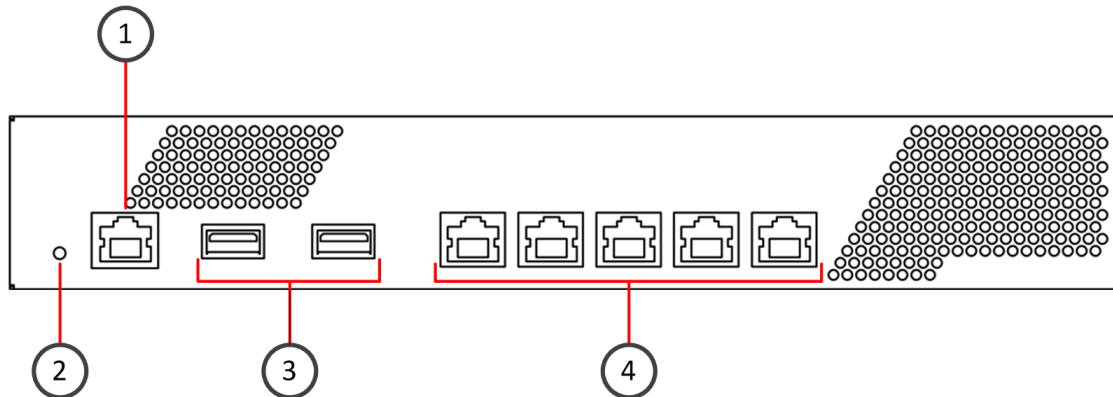

1. Console port (speed 9600 bps)
2. Power indicator light
3. USB ports
4. Fixed Ethernet ports

Back panel

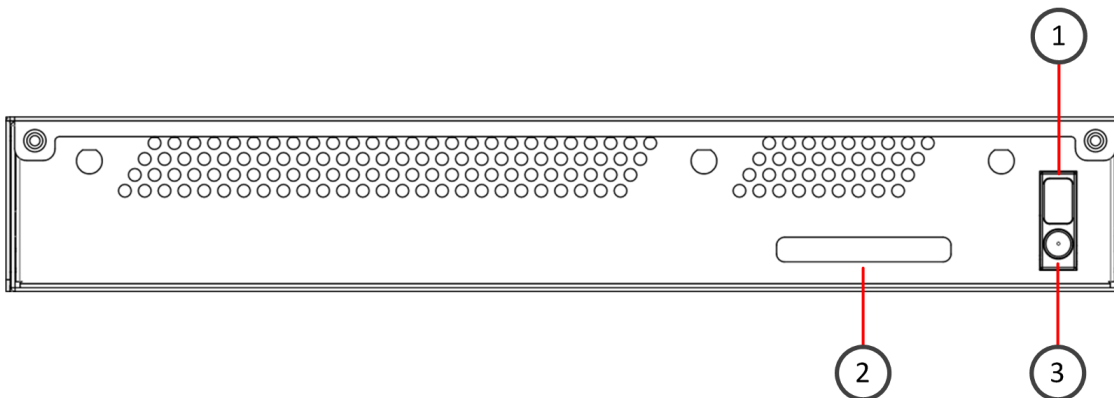

1. Power switch
2. CFast card
3. Power connector

Ethernet port names

321 appliances do not have removable interface modules. Ethernet port names are based on port number. The port numbers start from 0 and increase from left to right. *Example:* The port farthest to the left is eth0.

Indicator lights

321 appliances have one indicator light. When the power indicator is green, the system is operating normally and power is supplied to the system power supply unit.

Fixed Ethernet ports

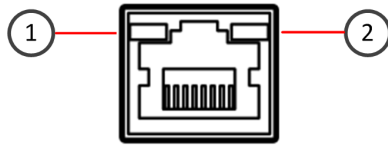

1. Activity indicator
2. Link indicator

Status	Description
Both indicators are unlit	No link.
Both indicators are lit	Link OK, activity indicator blinks on activity.

Model 325 features

The figures and tables show the appliance components.

Front panel

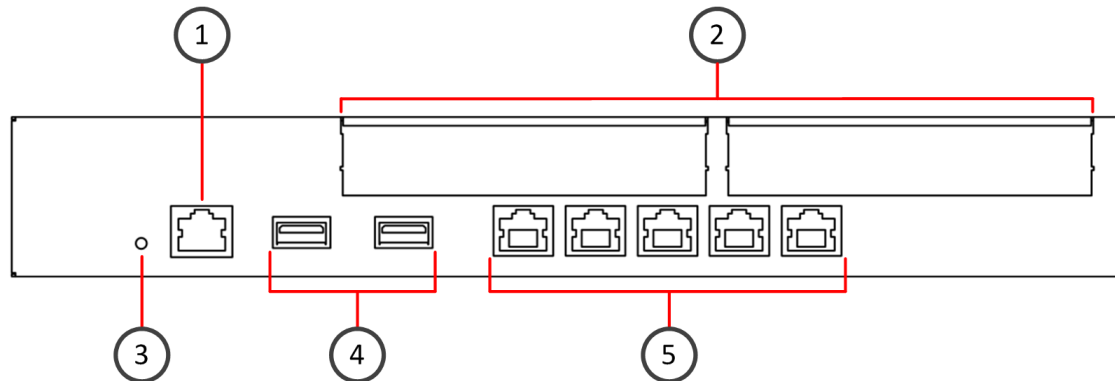

1. Console port (speed 9600 bps)
2. Interface modules
3. Power indicator light
4. USB ports
5. Fixed Ethernet ports

Back panel

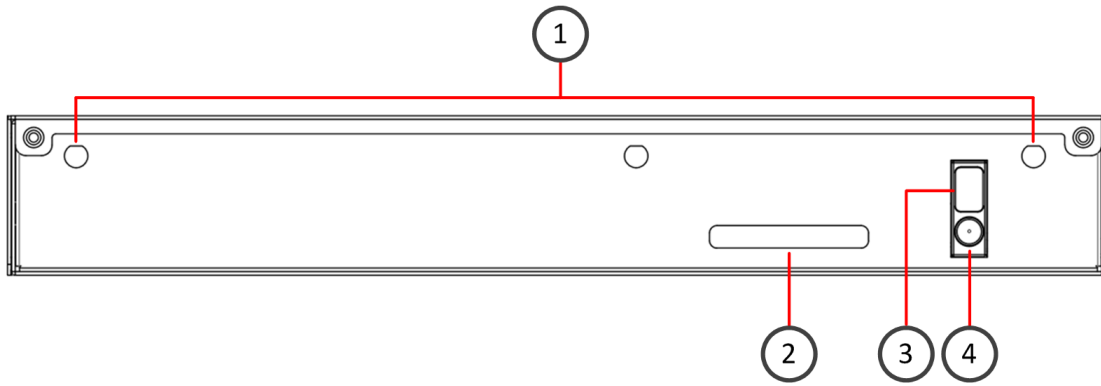

1. Antenna connectors
2. CFAST card
3. Power switch
4. Power connector

Ethernet port names

Ethernet port names are based on the slot and port numbers. The first number in the name represents the slot on the appliance. The second number represents the port on the slot. *Example:* eth2_0 is located on port 0 of slot 2.

Component	Slot number	Slot location	Port numbers
Fixed Ethernet ports	0	Front panel	eth0_0, eth0_1, eth0_2, eth0_3, and eth0_4.
Interface modules	1–2	Front panel	The port numbers start from 0 and increase from left to right. <i>Example:</i> The port farthest to the left in slot 1 is eth1_0.

Indicator lights

325 appliances have one indicator light. When the power indicator is green, the system is operating normally and power is supplied to the system power supply unit.

Fixed Ethernet ports

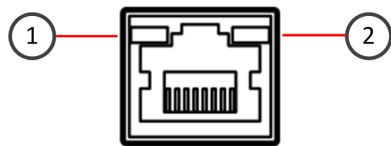

1. Activity indicator
2. Link indicator

Status	Description
Both indicators are unlit	No link.
Both indicators are lit	Link OK, activity indicator blinks on activity.

Model 1035 and 1065 features

The figures and tables show the appliance components.

Front panel

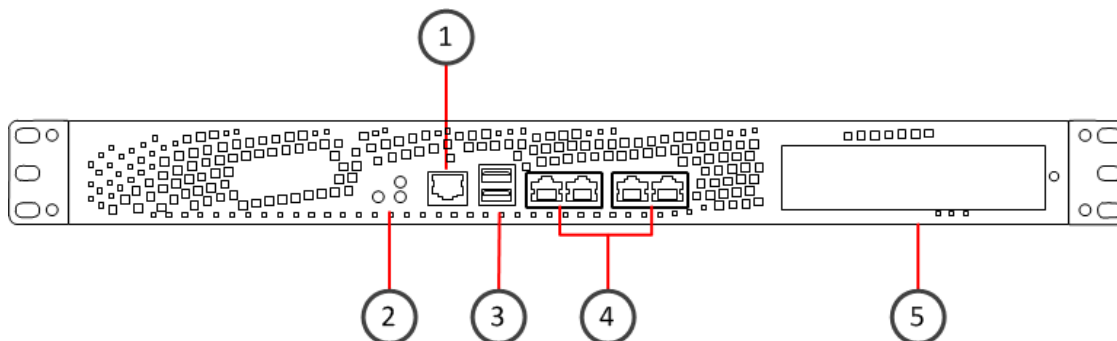

1. Console port (speed 9600 bps)
2. Power button and indicator lights
3. USB ports
4. Fixed Ethernet ports
5. Interface module

Back panel with an AC power supply

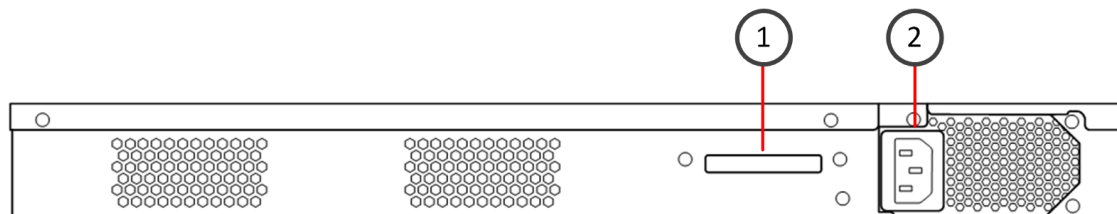

1. CFast card
2. AC power connector

Back panel with a dual input feed DC power supply

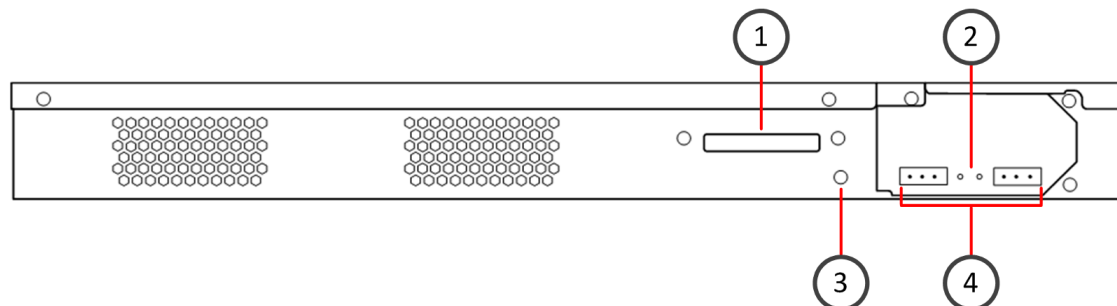

1. CFast card
2. Power indicators
3. (Optional) Grounding screw
4. DC power connectors

Ethernet port names

Ethernet port names are based on the slot and port numbers. The first number in the name represents the slot on the appliance. The second number represents the port on the slot. *Example:* eth2_0 is located on port 0 of slot 2.

Table 1: Ethernet slots and ports

Component	Slot number	Slot location	Port numbers
Fixed Ethernet ports	0	Front panel	eth0_0, eth0_1, eth0_2, and eth0_3.
Interface module	1	Front panel	The port numbers start from 0 and increase from left to right. <i>Example:</i> The port farthest to the left in slot 1 is eth1_0.

Indicator lights

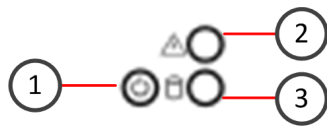

Number	Indicator	Status	Description
1	Power	Green	The appliance is in a running state.
		Amber	The appliance is in a standby state.
2	Warning	Red	Overheating. Blinks on fan failure.
3	Disk activity	Green	Indicates CFast card activity when flashing.

Fixed Ethernet port indicators

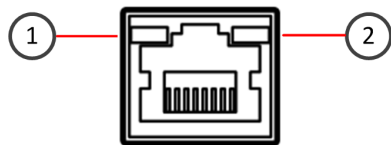

Number	Indicator	Status	Description
1	Activity/link indicator	Green	Link OK, blinks on activity.
2	Link speed indicator	Green	1 Gbps link.
		Amber	100 Mbps link.

Model 1401 and 1402 features

The figures and tables show the appliance components.

Front panel

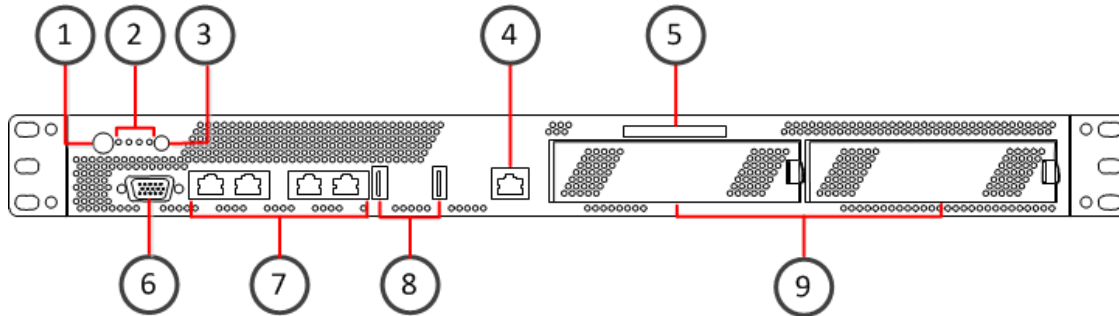

1. Power button
2. Indicator lights
3. UID button
4. Console port (speed 9600 bps)
5. CFAST card
6. VGA port
7. Fixed Ethernet ports
8. USB ports
9. Interface modules

Back panel

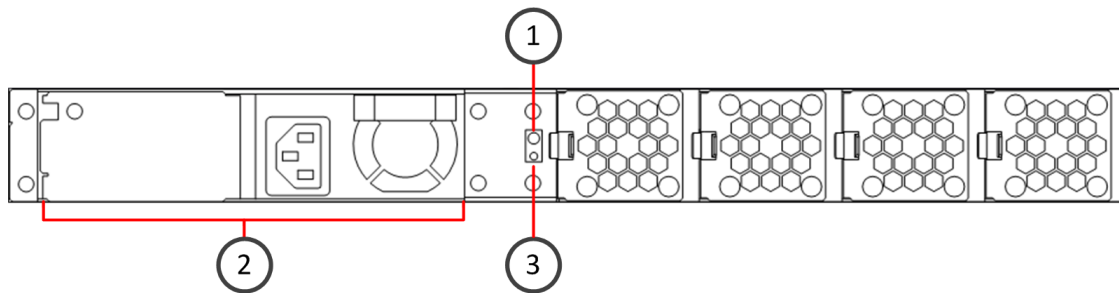

1. UID button
2. AC power connectors (two AC power connectors in model 1402)
3. UID indicator

Ethernet port names

Ethernet port names are based on the slot and port numbers. The first number in the name represents the slot on the appliance. The second number represents the port on the slot. *Example:* eth2_0 is located on port 0 of slot 2.

Component	Slot number	Slot location	Port numbers
Fixed Ethernet ports	0	Front panel	eth0_0, eth0_1, eth0_2, and eth0_3.
Interface modules	1–2	Front panel	The port numbers start from 0 and increase from left to right.

Component	Slot number	Slot location	Port numbers
			<i>Example:</i> The port farthest to the left in slot 1 is eth1_0.

Indicator lights

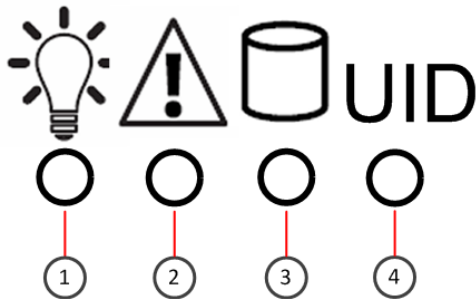

Number	Indicator	Status	Description
1	Power	Green	The appliance is in a running state.
		Red	The appliance is in a standby state.
2	Warning	Red	Overheating. Blinks on fan failure or system failure.
3	Disk activity	Yellow	Indicates CFast card activity when flashing.
4	UID	Blue	The UID indicator has been switched on.

Fixed Ethernet port indicators

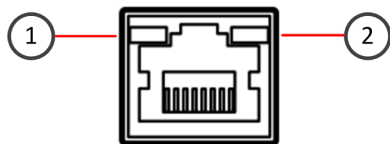

Number	Indicator	Status	Description
1	Activity/link indicator	Green	Link OK, blinks on activity.
2	Link speed indicator	Green	1 Gbps link.
		Amber	100 Mbps link.
		Off	10 Mbps link.

Interface modules

Stonesoft NGFW appliances support four types of modules.

- Copper
- Fiber
- Small form-factor pluggable (SFP)
- Placeholder



Note: Do not remove any stickers from modules — they contain important information.

Copper interface modules

Stonesoft NGFW appliances support these copper interface modules.

Dual-port modules

- MOD-EM1-10G-2 (10G2) — 10 gigabit interface module (not 325 appliances)
- MOD-10G-2-B (10G2B) — 10 gigabit bypass module (not 325 appliances)

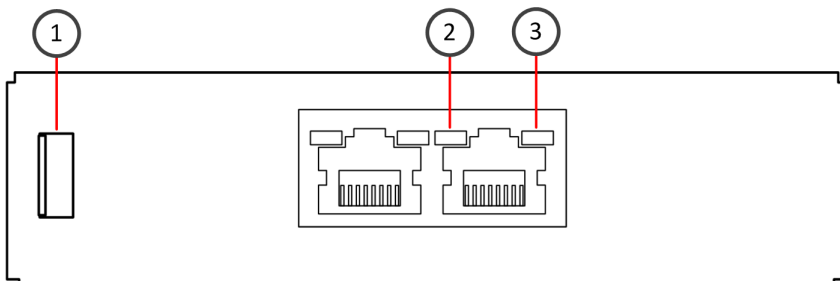

Number	Component	Color	Description
1	Release lever	N/A	N/A
2	Activity/link indicator	Green	Link OK, blinks on activity.
3	MOD-EM1-10G-2 (10G2) — Link speed indicator	Yellow	1 Gbps link.
		Green	10 Gbps link.
	MOD-10G-2-B (10G2B) — Link speed/bypass/disconnect indicator	Amber	1 Gbps link, blinks in disconnect mode.
		Green	10 Gbps link, blinks in bypass mode.

- MOD-MM-GE-2-B (GE2B) — Gigabit bypass module (325 appliances only)

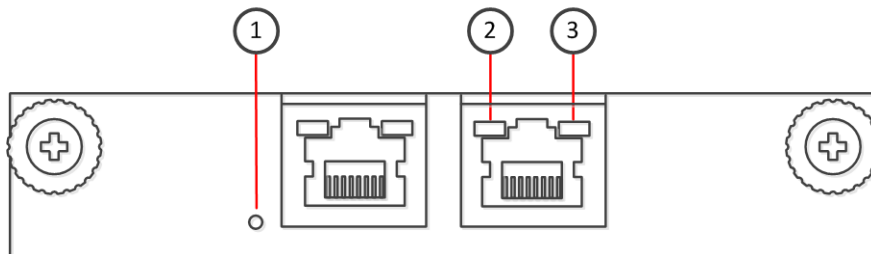

Number	Component	Color	Description
1	Bypass indicator	Amber	Bypass mode.
2	Activity/link indicator	Green	Link OK, blinks on activity.
3	Link speed indicator	Green	1 Gbps link.
		Amber	100 Mbps link.

Quad-port modules

- MOD-GE-4 (GE4) — Gigabit interface module (not 325 or 1401 appliances)
- MOD-GE-4-B (GE4B) — Gigabit bypass module (not 325 or 1401 appliances)

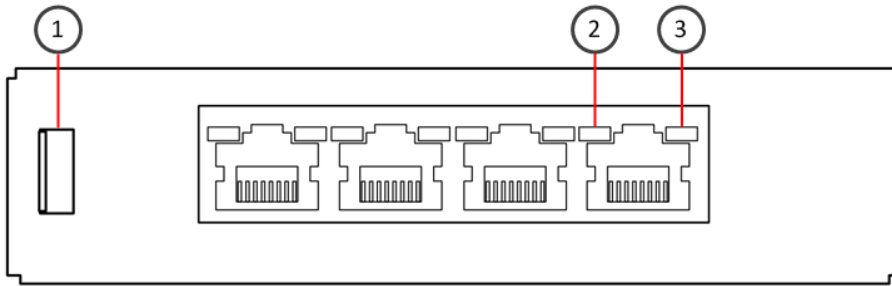

Number	Component	Color	Description
1	Release lever	N/A	N/A
2	Activity/link indicator	Green	Link OK.
3	MOD-GE-4 (GE4) — Link speed indicator	Green	1 Gbps link.
		Amber	100 Mbps link.
	MOD-GE-4-B (GE4B) — Link speed/bypass/disconnect indicator	Yellow	1 Gbps link, blinks in disconnect mode.
		Green	100 Mbps link, blinks in bypass mode.
	Unlit	10 Mbps link.	

- MOD-MM-GE-4 (GE4) — Gigabit interface module (325 appliances only)
- MOD-MM-FE-SW4 (SW4) — 100 megabit switch module (325 appliances only)

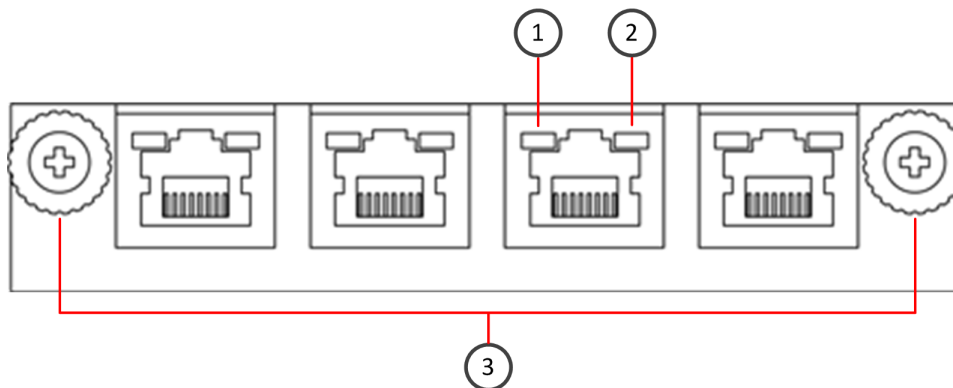

Number	Component	Color	Description
1	Activity/link indicator	Green	Link OK, blinks on activity.
2	MOD-MM-GE-4 (GE4) — Link speed indicator	Green	1 Gbps link.
		Amber	10 Mbps or 100 Mbps link.
	MOD-MM-FE-SW4 (SW4) — Link speed indicator	Amber	10 Mbps or 100 Mbps link.
3	Thumbscrews	N/A	N/A

Six-port gigabit interface module

- MOD-GE-6 (GE6)

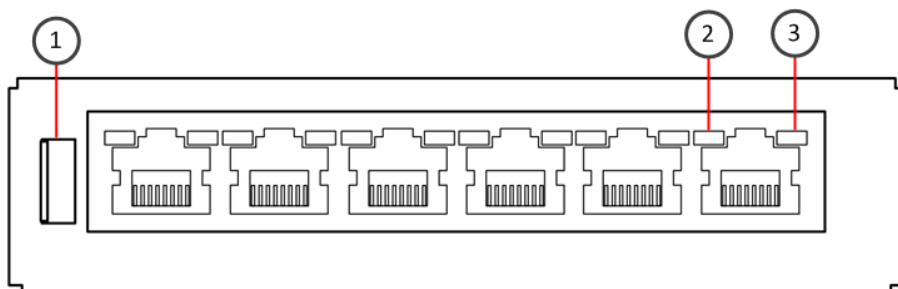

Number	Component	Color	Description
1	Release lever	N/A	N/A
2	Activity/link indicator	Green	Link OK.
3	Link speed indicator	Green	1 Gbps, 100 Mbps, or 10 Mbps link.

Eight-port gigabit interface module

- MOD-GE-8 (GE8) (not 325 appliances)

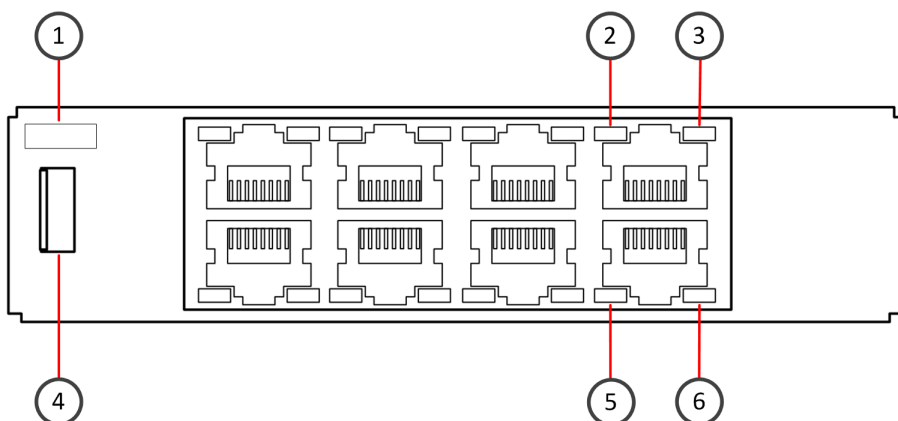

Number	Component	Color	Description
1	Port numbers 0–7	N/A	N/A
2, 5	Activity/link indicator	Green	Link OK, blinks on activity.
3, 6	Link speed indicator	Yellow	1 Gbps link.
		Green	100 Mbps link.
		Unlit	10 Mbps link.
4	Release lever	N/A	N/A

Fiber interface modules

Stonesoft NGFW appliances support these fiber interface modules.

Dual-port bypass modules

- MOD-GE-SX-2-B (GESX2B) — Gigabit bypass module (1035, 1065, and 1402 appliances only)
- MOD-10G-SR-2-B (10GSR2B) — 10 gigabit bypass module (1035, 1065, and 1402 appliances only)
- MOD-10G-LR-2-B (10GLR2B) — 10 gigabit bypass module (1035, 1065, and 1402 appliances only)

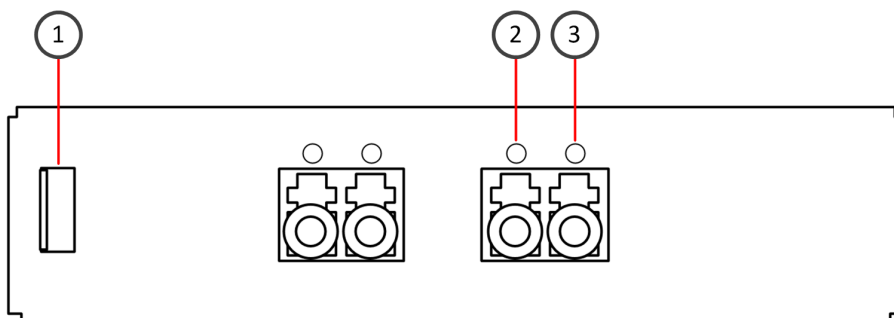

Number	Component	Color	Description
1	Release lever	N/A	N/A
2	Activity/link indicator	Green	Link OK.
3	MOD-10G-SR-2-B, MOD-10G-LR-2-B — Link speed/bypass/disconnect indicator	Blue	10 Gbps link.
		Green	Blinks in bypass mode.
	MOD-GE-SX-2-B — Link speed/bypass/disconnect indicator	Green	1 Gbps link, blinks in bypass mode.
		Yellow	Blinks in disconnect mode.

Quad-port gigabit bypass module

- MOD-GE-SX-4-B (GESX4B) (1035, 1065, and 1402 appliances only)

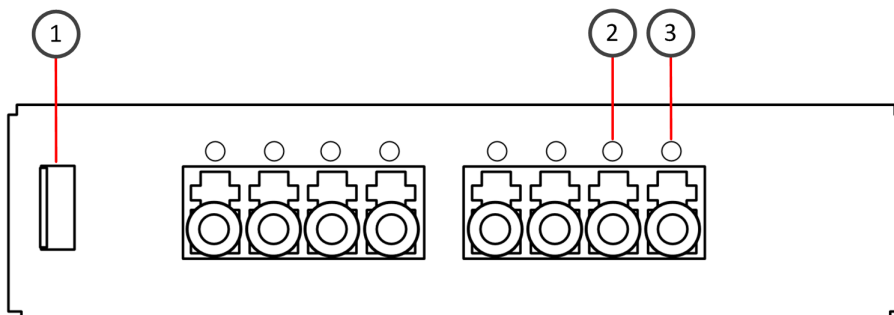

Number	Component	Color	Description
1	Release lever	N/A	N/A
2	Activity/link indicator	Green	Link OK.
3	Link speed/bypass/disconnect indicator	Green	1 Gbps link, blinks in bypass mode.

Number	Component	Color	Description
		Yellow	Blinks in disconnect mode.

SFP interface modules

Stonesoft NGFW appliances support these SFP interface modules.

Single-port gigabit interface module (SFP)

- MOD-MM-GE-SFP (325 appliances only)

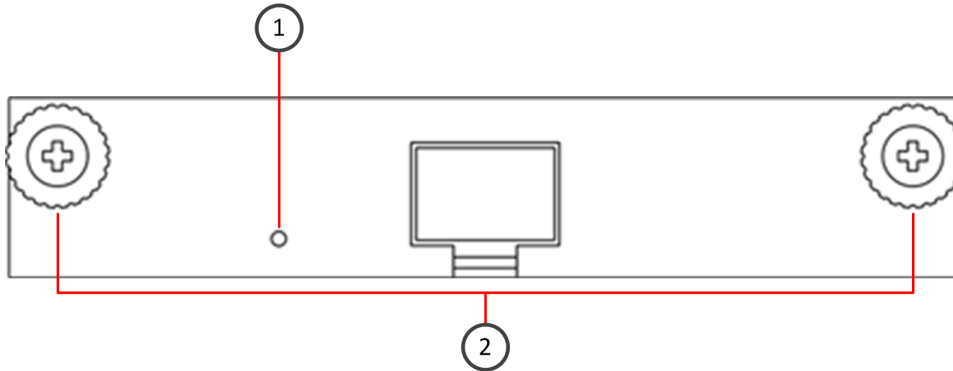

Number	Component	Color	Description
1	Activity/link/link speed indicator	Green	1 Gbps link (other speeds not supported), blinks on activity.
2	Thumbscrews	N/A	N/A

Dual-port interface modules

- MOD-10G-SFP-2 (10GSFP2) — 10 gigabit interface module (SFP+) (1065, 1401, and 1402 appliances only)

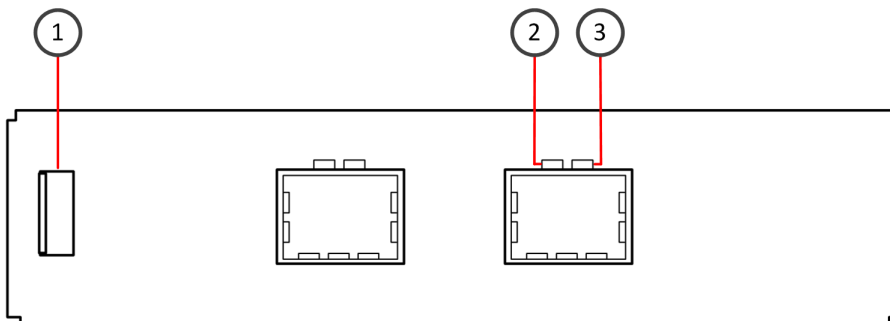

Number	Component	Color	Description
1	Release lever	N/A	N/A
2	Activity/link indicator	Green	Link OK.
3	Link speed indicator	Blue	10 Gbps link.

- MOD-40G-2 — 40 gigabit interface module (QSFP+) (1401 and 1402 appliances only)

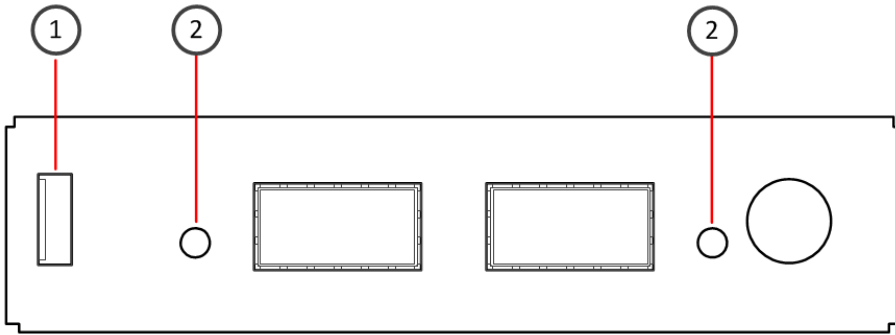

Number	Component	Color	Description
1	Release lever	N/A	N/A
2	Activity/link/link speed indicator	Green	40 Gbps link (other speeds not supported), blinks on activity.

Quad-port interface modules

- MOD-GE-SFP-4 (GE4SFP) — Gigabit interface module (SFP) (not 321 or 325 appliances)
- MOD-10G-SFP-4 (10GSFP4) — 10 gigabit interface module (SFP+) (1065, 1401, and 1402 appliances only)
- MOD-EM2-10G-SFP-4 — 10 gigabit interface module (SFP+) (1401 and 1402 appliances only)

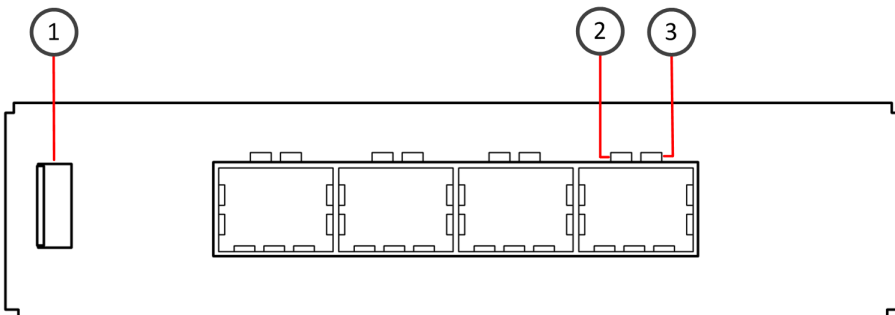

Number	Component	Color	Description
1	Release lever	N/A	N/A
2	Activity/link indicator	Green	Link OK.
3	MOD-GE-SFP-4 (GE4SFP) — Link speed indicator	Yellow	1 Gbps link.
	MOD-10G-SFP-4 (10GSFP4) — Link speed indicator	Blue	10 Gbps link.
	MOD-EM2-10G-SFP-4 — Link speed indicator	Blue	10 Gbps link.

Placeholder modules

A placeholder module (MOD-PH) does not contain a network interface card or any ports.

If you do not have interface modules that contain a network interface card for all slots in the modular appliance, you must insert placeholder modules in the remaining slots.

Precautions

The precautions provide safety guidance when working with Forcepoint appliances and electrical equipment.

Safety precautions

Read the safety information and follow the procedures whenever you are working with electronic equipment.



CAUTION: Forcepoint appliances cannot be serviced by end users. Never open the appliance covers for any reason. Doing so can lead to serious injury and void the hardware warranty.

General safety

Follow these rules to ensure general safety.

- Keep the area around the appliance clean and free of clutter.
- Use a regulating uninterruptible power supply (UPS) to keep your system operating if there is a power failure and to protect the appliance from power surges and voltage spikes.
- If you need to switch off or unplug the appliance, always wait at least five seconds before turning on or plugging in the appliance again.

Operating precautions

Do not open the power supply casing. Only the manufacturer's qualified technician can access and service power supplies.

Electrical safety precautions

Follow basic electrical safety precautions to protect yourself from harm and the appliance from damage.

- Know the locations of the power on/off button and the emergency turn-off switch, disconnection switch, or electrical outlet for the room. If an electrical accident occurs, you can quickly turn off power to the system.
- When working with high-voltage components, do not work alone.
- Turn off the system and disconnect the power before removing or installing system components.
- When working with electrical equipment that is turned on, use only one hand. This is to avoid making a complete circuit, which causes an electric shock. Use extreme caution when using metal tools, which can easily damage any electrical components or circuit boards the tools come into contact with.
- Do not use mats designed to decrease electrostatic discharge as protection from electric shock. Instead, use rubber mats that have been designed as electrical insulators.
- The power supply cable must include a grounding plug and must be plugged into a grounded electrical outlet.

Power supply safety precautions

Depending on the type of power supply that your Stonesoft NGFW appliance uses, different safety precautions and installation guidelines apply.

AC power supplies

The appliance has 1–2 connectors for an AC power supply. The appliance inlet is the disconnect device.

DC power supplies

- The appliance must be used in a restricted access location and users must be well trained to operate it.
- The outlet for the appliance must be installed near the appliance and be easily accessible.
- We recommend using, at maximum, a 10A fuse and a power switch between the appliance and the main power source.
- The appliance must be protected against electric shock and must have, at minimum, a 15 AWG wire provided for the DC power supply.
- The mains supply plug on the power supply cable is the disconnect device on the appliance. To disconnect the appliance, you must first disconnect the mains, then disconnect the ground.
- The female and the male connectors of the DC power supply must be easy to disconnect.



Note: 1035 and 1065 appliances that have a dual input feed DC power supply might cause, at maximum, a 500 mA current from one input feed to another. This occurs only when the voltages at the appliance's input feeds are the same and power is no longer supplied by one of the power sources.



Note: Standby power is supplied to the 321 and 325 appliances even when the appliance is turned off.

Install the appliance

Prepare and install the appliance in your network.

- You have installed a Stonesoft Management Center (SMC) on a separate server.
- You have configured the Security Engine element (Firewall, IPS, or Layer 2 Firewall) in the Management Client, and saved the initial configuration on a USB drive.



Note: For additional information on SMC installation and initial configuration, see the *Stonesoft Next Generation Firewall Installation Guide*.

- You have inspected the appliance, the delivery box, and all components included in the shipment.



Note: Do not use damaged appliances or components.



Note: 321 and 325 appliances do not require rack-mounting and can be placed on a surface such as a desk or rack shelf.

Install an interface module

If needed, install any interface modules.

- Read the safety precautions.
- To avoid damaging the modules or the appliance, do not install or remove any interface modules if the appliance is turned on.
- Make sure any interface modules you install are the correct type for your appliance.

You must install an interface module or a placeholder module in each slot before making the appliance operational. For 325, 1035, and 1065 appliances, you can cover the interface slot with the plate that shipped with the appliance.



Note: We recommend fastening a grounding strap to your wrist so that it contacts your bare skin and attaching the other end of the strap to the appliance.

1. Locate the slot to install the module in.
2. (325, 1035, and 1065 appliances) Unfasten the thumbscrew that attaches the plate to the interface module slot and remove the plate.

Store the plate and the thumbscrew for later use in case you want to use the appliance without an interface module.

3. Push the module into the slot.

The module is seated correctly when the front panel of the module is even with the front panel of the appliance.



Tip: If the module has a sticker, make sure that the sticker faces down for 325 appliances. For other 1U appliances, the sticker faces up.



Important: Do not insert the module in the wrong orientation. Inserting the modules incorrectly might damage the appliance and the modules and voids the warranty.

4. (325 appliances only) Turn the thumbscrews on the module to secure the module in place.

Rack-mount the appliance

The rack-mounting procedure varies depending on the type of rack unit. If needed, see the documentation for your rack unit.



Important: Read the safety precautions before you rack-mount the appliance. Do not install the appliance upside down.

You can install the appliance into a two-post, a four-post, or a Telco-type rack unit. You can place 321 and 325 appliances on a horizontal surface such as a desk or rack shelf.

Preparing for rack-mounting

The rack-mounting kit includes the mounting screws and the rail assemblies or rack-mounting brackets to install the system into the rack.

Determine the placement of each component in the rack.

- Install the heaviest components on the bottom of the rack first. Install components from the bottom to the top.
- The appliance must be connected to a grounded power outlet.
- Use a UPS to protect the appliance from power surges and voltage spikes, and to keep your system operating if there is a power failure.
- To maintain proper cooling, always keep the front door of the rack and all panels and components on the appliances closed when not servicing.

Install a 321 or 325 appliance in a four-post rack

Use the rack-mounting brackets to secure the appliance in the rack.

The brackets and screws are not included by default. You can order them separately.

1. Locate the brackets for the four-post rack installation.

The bracket delivery includes one power supply mounting bracket and two side brackets of different sizes. The larger side bracket is for 321 appliances and the smaller for 325 appliances. The delivery also includes a cover plate for the power supply mounting bracket.



Tip: You can use the power supply mounting bracket for storing a power supply.

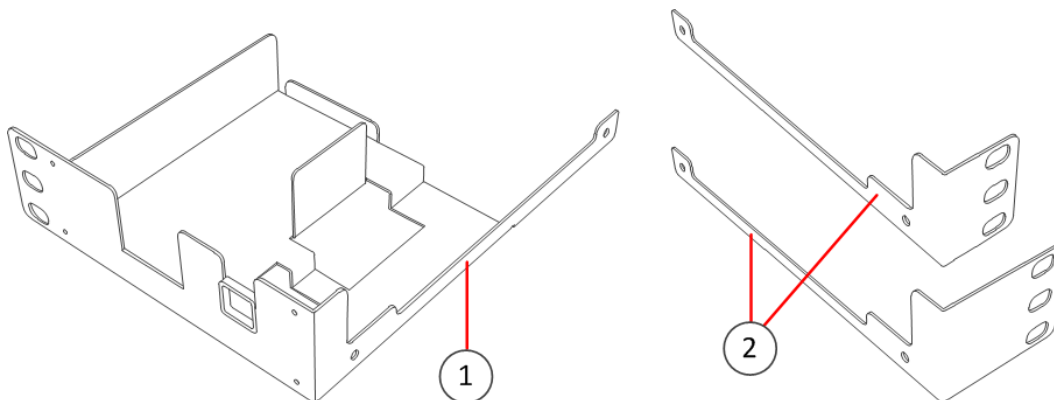

1. Power supply mounting bracket

2. Side brackets

2. Unscrew the pair of screws from both sides of the appliance.



CAUTION: Do not reuse these screws for attaching the brackets. The screws are not long enough to properly attach the brackets.

3. Attach the power supply mounting bracket to the left side of the appliance with two screws through the holes in the side of the bracket.

The narrow part of the bracket attaches toward the back of the appliance.



Note: Use two screws to attach the rack-mounting bracket to the appliance. Using only a single screw does not provide sufficient support and can damage the appliance.

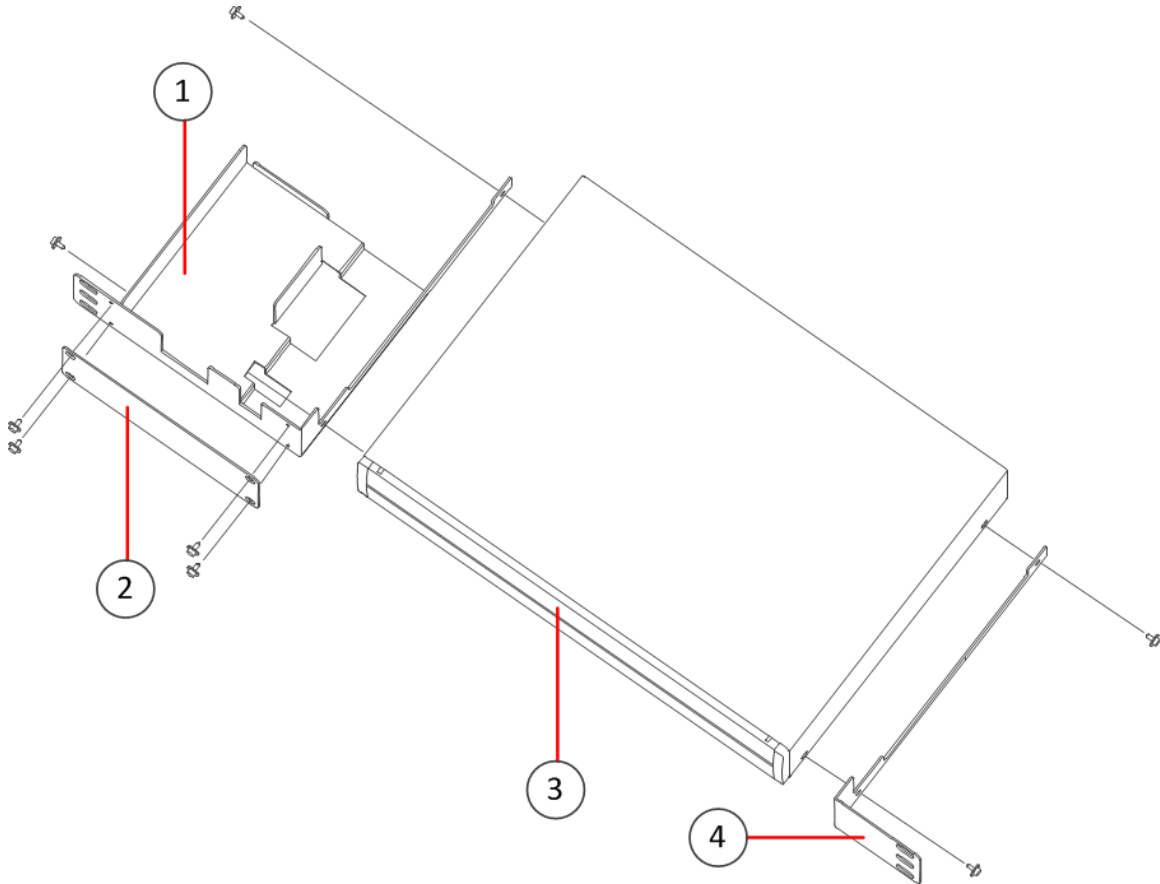

1. Power supply mounting bracket
2. Cover plate
3. Front panel
4. Side bracket

4. (Optional) Attach the cover plate to the front of the power supply mounting bracket with four screws through the holes in the cover plate.



Note: If you want to use the power supply mounting bracket for storing a power supply, do not cover the front of the bracket with the cover plate.

5. Attach the side bracket to the right side of the appliance with two screws through the holes in the side of the bracket.

The narrow part of the bracket attaches toward the back of the appliance.



Note: Use two screws to attach the rack-mounting bracket to the appliance. Using only a single screw does not provide sufficient support and can damage the appliance.

6. Attach each bracket to the rack with three screws through the holes in the front of the bracket: one screw through the top hole, the second through the middle hole, and the third through the bottom hole.



CAUTION: Use at least two screws to attach each rack-mounting bracket to the rack. Using fewer screws might not provide sufficient support and can damage the appliance.

Install a 1035 or 1065 appliance in a two-post rack

Use the rack-mounting brackets to secure the appliance in the rack.

When installing the appliance into a two-post Telco-type rack, you must move the rack-mounting brackets into the correct position on the side of the appliance before attaching the rack-mounting brackets to the rack.

1. Detach the rack-mounting brackets from the appliance by removing the screws on each side of the appliance. There are six screws on each side.



Tip: You can optionally remove the lifting handle from the bracket by removing the screws that hold the handle to the bracket.



2. Move a bracket to the back of both sides of the appliance and reattach the brackets. Use three screws for each bracket.

We recommend reattaching the six remaining screws to the front of the appliance: three on each side of the appliance.



3. Attach each bracket to the rack using two screws and cage nuts. Insert the screws through the holes in the front of the bracket: one screw through the top hole and another through the bottom hole in the bracket. See the front panel illustration for the location of the holes.

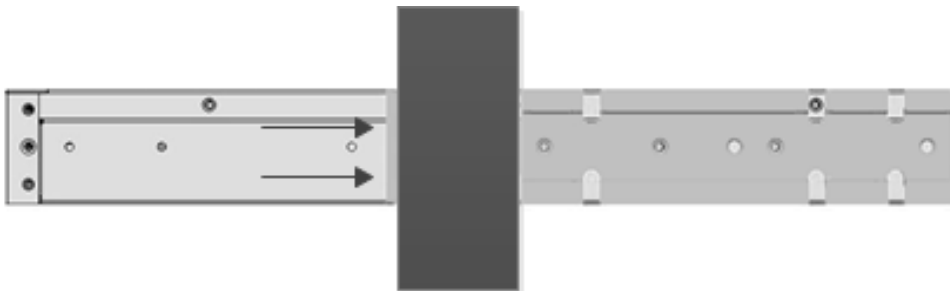

CAUTION: Use two screws to attach each rack-mounting bracket to the rack. Using only a single screw for each bracket does not provide sufficient support and can damage the appliance.

Install a 1035 or 1065 appliance in a four-post rack

Use the rack-mounting brackets to secure the appliance in the rack.



Note: If you are installing the appliance into a four-post Telco-type rack, the rack-mounting brackets on the appliance are in the correct position for installation.

1. Attach a rack-mounting bracket to the rack using two 6 millimeter screws and cage nuts. Insert the screws through the holes in the front of the bracket: one screw through the top hole and another through the bottom hole in the bracket.

See the front panel illustration for the location of the holes.



Note: Use two screws to attach each rack-mounting bracket to the rack. Using only a single screw for each bracket does not provide sufficient support and can damage the appliance.

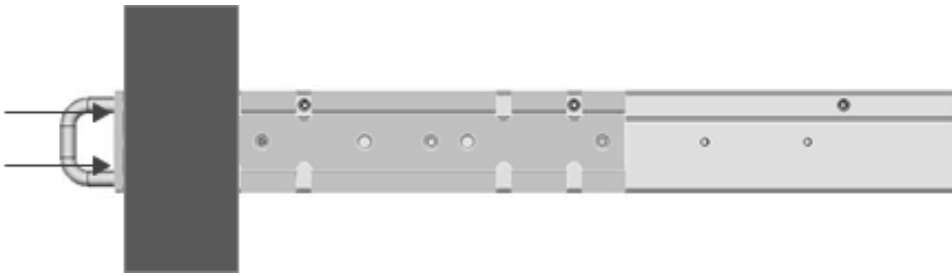

2. Install the bracket on the other side of the appliance.

Install a 1401 or 1402 appliance in a two-post rack

Use the rack-mounting brackets to secure the appliance in the rack.

1. Locate the two rack-mounting brackets for the two-post rack installation.

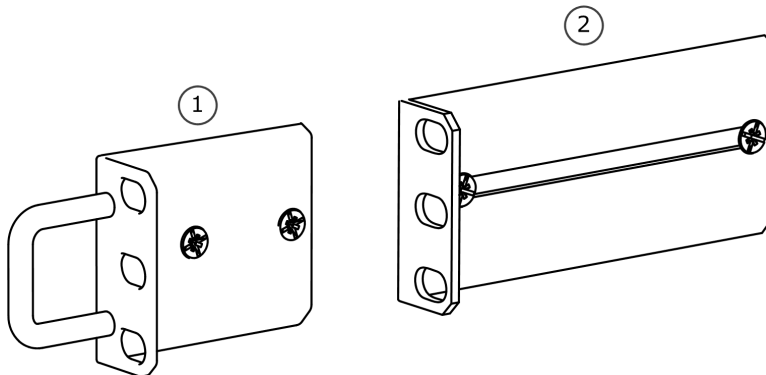

2. Attach a bracket to each side of the appliance with screws through the grooves in the bracket. Position the brackets to fit around the posts.

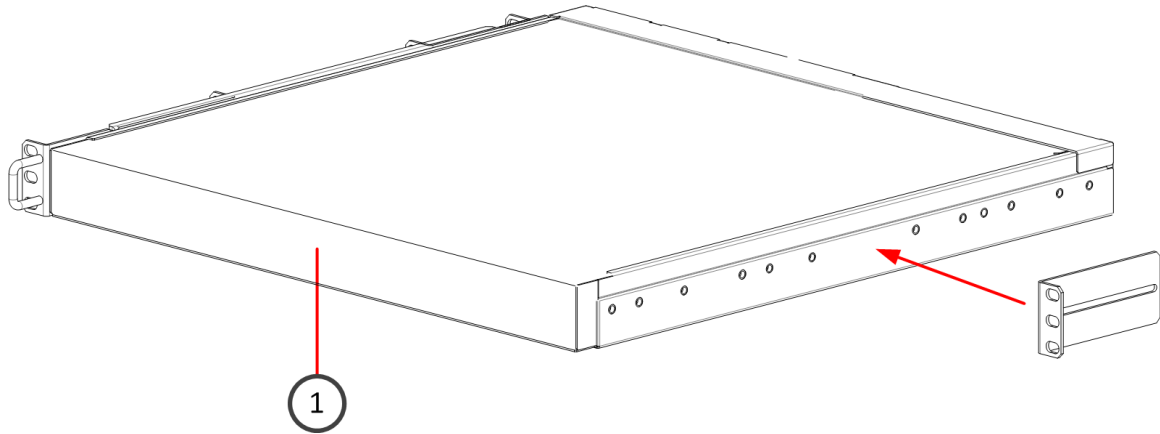

1. Front panel

3. Attach each bracket to the rack with three screws through the holes in the front of the bracket: one screw through the top hole, the second through the middle hole, and the third through the bottom hole.



CAUTION: Use all three screws to attach each rack-mounting bracket to the rack. Using fewer screws might not provide sufficient support and can damage the appliance.

Install a 1401 or 1402 appliance with medium-length brackets in a four-post rack

Use the medium-length brackets (with a depth of approximately 20–30 in. or 50–76 cm) to secure the appliance in a four-post rack.

1. Locate the two pairs of brackets in the delivery package: two short brackets that attach to the appliance and two medium brackets that attach to the rack.

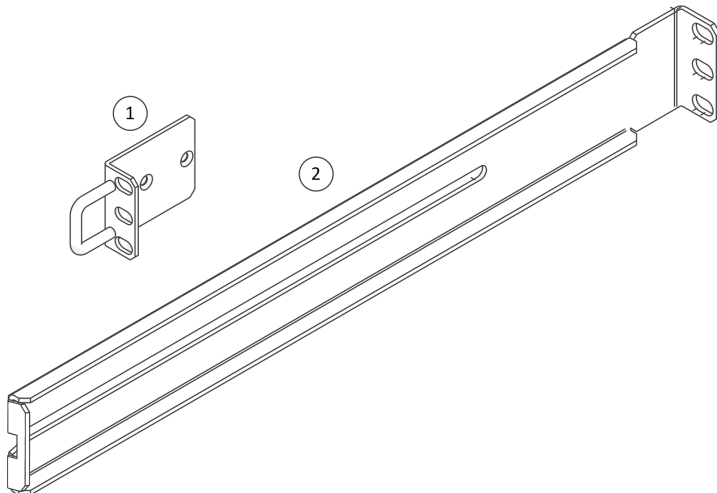

1. Short bracket (attaches to the appliance)
2. Medium bracket (attaches to the rack)

2. Attach a short bracket to both sides of the appliance using two screws for each bracket.

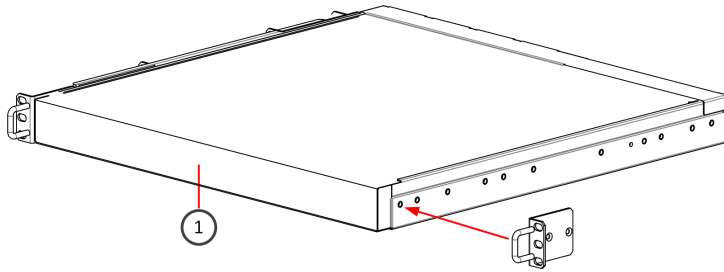

1. Front panel

3. Attach the two medium brackets to the back of the rack with three screws through the holes at the back of each bracket: one screw through the top hole, another through the middle hole, and the third through the bottom hole.



CAUTION: Use all three screws to attach each rack-mounting bracket to the rack. Using fewer screws might not provide sufficient support and can damage the appliance.

4. Attach two or three screws with a wider head to a suitable position on the side of the appliance. Do the same for the other side of the appliance.



Note: These screws support the appliance when it is inserted into the rack. The number and position of the screws depends on the depth of the rack.

5. Line up the screws that you have attached to the appliance with the groove in the brackets attached to the rack.
6. Slide the appliance into the brackets in the rack.
7. Attach the appliance to the rack with three screws through the holes in the front of the short brackets: one screw through the top hole, the second through the middle hole, and the third through the bottom hole.



CAUTION: Use all three screws to attach each rack-mounting bracket to the rack. Using fewer screws might not provide sufficient support and can damage the appliance.

Install a 1401 or 1402 appliance with long brackets in a four-post rack

Use the long brackets (with a depth of approximately 27–34 in. or 70–100 cm) to secure the appliance in a four-post rack.

1. Locate the two pairs of brackets in the delivery package: two inner rails that attach to the appliance and two outer rails that attach to the rack.

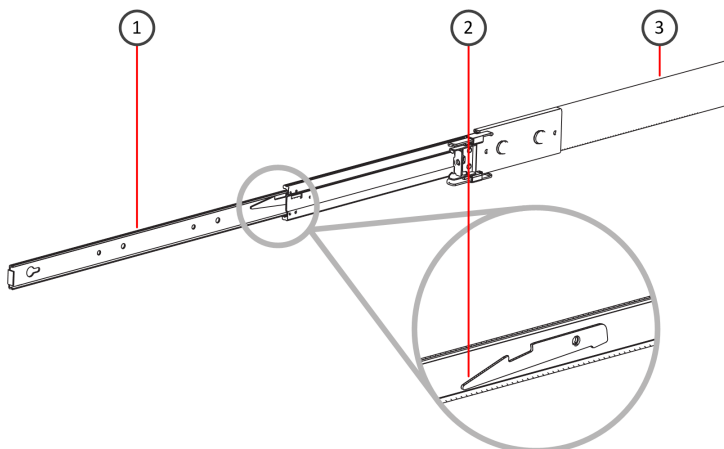

1. Inner rail
2. Locking tab
3. Outer rail

2. Detach the inner rails from the outer rails. Press down the locking tab to pull out the inner rail.
3. Attach an inner rail to each side of the appliance using four screws for each rail.
 - The inner rails are marked with "LH" for left and "RH" for right.
 - The outer rails are marked with "Front" for the front end and "Rear" for the rear end.
 - The outer rail that was attached to the inner rail marked "LH" must be attached to the left side of the rack, and the outer rail that was attached to the inner rail marked "RH" must be attached to the right side of the rack.

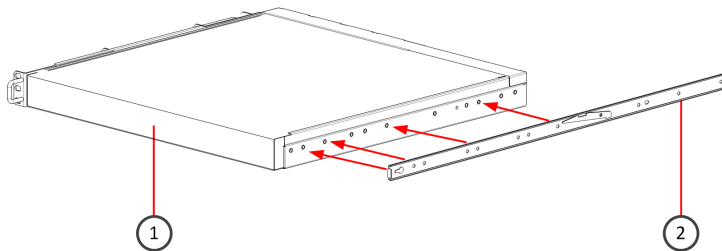

1. Front panel
2. Inner rail

4. Release the safety lock on the front end of an outer rail by pulling it back.

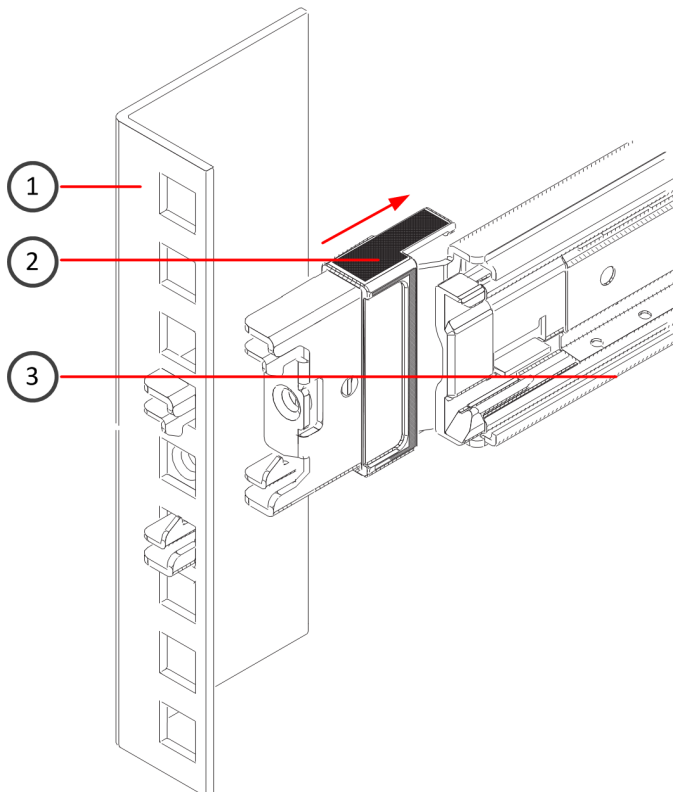

1. Rack
2. Safety lock
3. Outer rail

5. Insert the outer rail into the rack.

If the ends of the outer rails do not fit into the holes in the rack, use the adapter brackets included in the delivery.

6. Push the safety lock forward to secure the rail into the rack.
7. Insert the other outer rail into the rack.
8. Line up the rear of the inner rails with the front of the outer rails.
9. Slide the inner rails into the outer rails, keeping the pressure even on both sides. You might have to press the locking tabs when inserting.

The rails lock into the rack when the appliance is pushed completely into the rack.

Connect the cables

Connect the network, management, and power supply cables.

Network settings and cables

Follow these network settings and cable guidelines.

Copper cable types

Use at least CAT5e-rated cables for gigabit networks.

(IPS and Layer 2 Firewall only) Always use standard cabling methods. Use crossover cables to connect the appliance to hosts and straight cables to connect the appliance to switches or hubs.

Speed and duplex settings

Network interfaces at both ends of each cable must have identical speed and duplex settings. This includes the automatic negotiation setting. If one end of the cable uses autonegotiation, the other end must also use autonegotiation. Gigabit standards require interfaces to use autonegotiation — fixed settings are not allowed at gigabit speeds.

(IPS and Layer 2 Firewall only) The settings for inline interfaces must be identical. All four interfaces — the pair on the appliance and the interfaces on the two devices connecting to the appliance — must have the same speed and duplex settings configured.

Ethernet port mapping

For appliances that have removable interface modules, Ethernet port names are based on the slot and port numbers. The first number in the name represents the slot on the appliance, and the second number represents the port on the slot. *Example:* eth2_0 is located on port 0 of slot 2.

- Slot 0 contains the fixed Ethernet ports.
- Slots 1 and higher contain the ports on the interface modules. The port numbers start at 0 and increase from left to right.

During the initial configuration of the appliance, the Ethernet ports are mapped to the interface IDs that you defined in the Management Client.

The NGFW Configuration Wizard displays the mapping between the interface IDs and port names. Interface IDs appear in the **Id** column and port names appear in the **Name** column.

This mapping can change if you replace an interface module. If the new module has a larger number of Ethernet ports, the interface IDs for the new ports start from the next free interface ID number. Use the new interface IDs to configure new interfaces in the Management Client, then refresh the policy on the engine to transfer the changes. See the *Stonesoft Next Generation Firewall Product Guide (McAfee SMC Administrator's Guide for version 5.8 or earlier)* for more information.



CAUTION: Do not select the **Clear** action when modifying interface IDs in the NGFW Configuration Wizard. Selecting **Clear** removes all mapping information between interface IDs and Ethernet ports, and restores the default values.

Example: You have seven interfaces numbered 1–7, which includes a four-port module installed in slot 1.

```

Step 2 of 3: Configure network
  Id  Name  Driver  Link  Media
  ---  ---  ---  ---  ---
  0  eth0_0  igb  up  <Auto/1000/FD>
  1  eth0_1  igb  down  <Auto>
  2  eth1_0  igb  bp  <Auto>
  3  eth1_1  igb  bp  <Auto>
  4  eth1_2  igb  bp  <Auto>
  5  eth1_3  igb  bp  <Auto>
  6  eth2_0  ixgbe  down  <Force>
  7  eth2_1  ixgbe  down  <Force>
  <Add..>  <Autodetect..>  <Initia
  
```

Figure 1: Original interface ID mapping

If you replace the four-port module installed in slot 1 with a two-port module, eth1_2 with ID 4 and eth1_3 with ID 5 are removed.

```

Step 2 of 3: Configure network
  Id  Name  Driver  Link  Media
  ---  ---  ---  ---  ---
  0  eth0_0  igb  up  <Auto/1000/FD>
  1  eth0_1  igb  down  <Auto>
  2  eth1_0  igb  bp  <Auto>
  3  eth1_1  igb  bp  <Auto>
  4  eth2_0  ixgbe  down  <Force>
  5  eth2_1  ixgbe  down  <Force>
  <Add..>  <Autodetect..>  <Initia
  
```

Figure 2: Changed interface ID mapping

Connect network and management cables

Connect the appliance to your networks. The management connection allows you to view the system console.



Note: Ethernet ports are mapped to interface IDs during the initial configuration. The ports and port numbers of the physical appliance must match the interface definitions and interface IDs configured for the engine in the Management Client.

1. Determine which Ethernet ports to use and connect the ports to your networks.
2. Select one of these options for the management connection:
 - **321, 325, 1035, and 1065 appliances** — Connect the supplied null-modem cable to the console port on the front panel of the appliance and to another computer for a terminal connection.
 - **1401 and 1402 appliances** — Connect a monitor to the VGA port on the front panel of the appliance and a keyboard to a USB port.



Note: The serial console is not enabled by default on 1401 and 1402 appliances and cannot be used for the initial configuration. To use the serial console after the initial configuration, use the command `sg-bootconfig` on the engine command line. For more information, see *Command line tools* in the *Stonesoft Next Generation Firewall Product Guide (McAfee SMC Administrator's Guide for version 5.8 or earlier)* for more information.

Connect network cables to SFP ports

If you installed an SFP interface module on the appliance, insert the copper or fiber-optic SFP transceiver into the module and connect the cables.

1. Insert the SFP transceiver in the port slot until you feel the connector on the transceiver snap into place.



Note: Make sure that the latch on the SFP transceiver is up when you insert the SFP transceiver in the port slot.

2. If the SFP transceiver has a rubber plug, remove the plug.
3. Connect the copper or fiber-optic cable to the SFP transceiver.



Note: Each SFP port must match the wavelength specifications at the other end of the cable. The cable must not exceed the stipulated cable length for reliable communications.

Connect the antennas

325 appliances have WLAN support.

1. Install the antennas to the two connectors on the back panel of the appliance.
2. Tighten the knurled nuts at the base of the antennas to secure them firmly to the appliance.
3. Position the antennas.

Connect the power supplies

1035 and 1065 appliances might have an AC power supply or a DC power supply with a dual feed input adapter. See *Safety precautions* for more information about power supplies.

Connect the AC power supply

If your appliance has an AC power supply, connect the power cable.



Note: We recommend using a UPS to ensure continuous operation and minimize the risk of damage to the appliance in case of sudden loss of power.

1. Plug the cable to the AC power connector on the back of the appliance.
2. Plug the cable to a grounded, high-quality power strip that offers protection from electrical noise and power surges.



Note: Standby power is supplied to the system even when the appliance is turned off.

Connect the DC power supply

Some 1035 and 1065 appliances have a DC power supply with a dual input feed adapter that must be wired for power.

Two types of connectors are required for a DC power supply that has a dual input feed adapter:

- Male connector of the type IC 2,5/ 3-STGF-5,08 (fixed)
- Female connector of the type MSTB 2,5/ 3-STF-5,08 (removable)

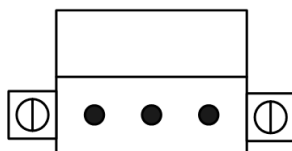

Figure 3: Male connector

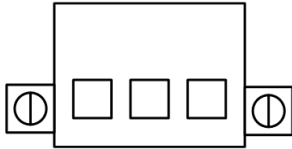

Figure 4: Female connector



Note: We recommend using a UPS to ensure continuous operation and minimize the risk of damage to the appliance in case of sudden loss of power.

1. Assemble a female connector.

1. Locate a copper cable with three wires:

- 48 V negative terminal (-)
- Ground connection
- 48 V positive terminal (+)

2. Strip 8 mm of insulation from each of the three wires in the cable.



CAUTION: Do not strip more than 8 mm from each wire to avoid leaving uninsulated wire exposed from the female connector.

3. If necessary, turn the screws on top of the female connector to expose the square holes for inserting the three wires in the connector.

4. Insert the exposed part of each of the three wires into the female connector. The illustration shows the wiring.

You can configure the DC input feed in three different ways, depending on your environment:

- Negative grounded (+48VDC)
- Positive grounded (-48VDC)
- Floating (default)

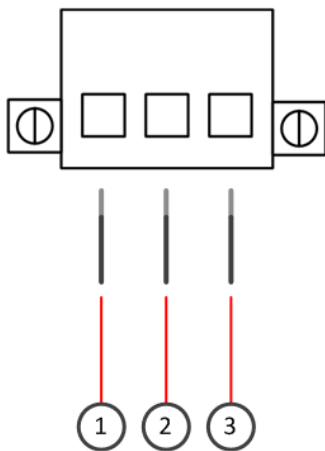

1. 48 V negative terminal (-)
2. Ground connection
3. 48 V positive terminal (+)

5. Tighten the screws on top of the female connector to lock the wires into place.

6. Assemble the second female connector.

2. Connect the mating connectors.

1. Insert a female connector into the pre-installed male connector as shown in the illustration.

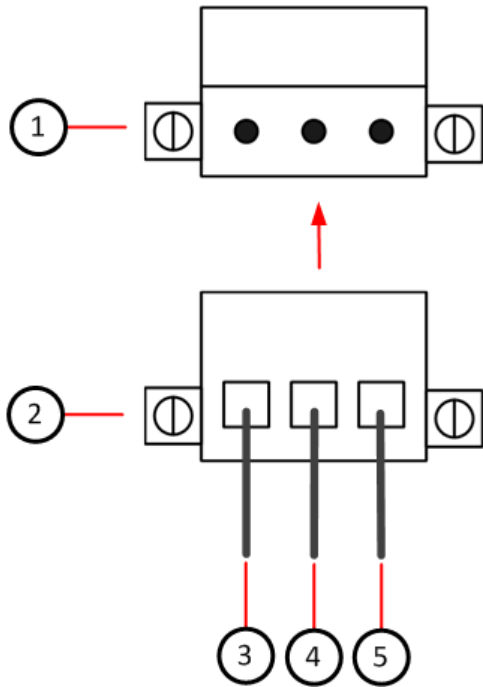

1. Pre-installed male connector
2. Female connector
3. Black or blue
4. Green-yellow
5. Red

2. Connect the second female connector to the male connector.
3. (Optional) Connect a grounding wire to the grounding screw on the back of the appliance.



Note: Standby power is supplied to the system even when the appliance is turned off.

Maintenance

Stonesoft NGFW appliances ship with several replaceable components.

Turn off the appliance

Stonesoft NGFW 1U appliance hardware components are not hot-swappable. Turn off the appliance and disconnect power before replacing any hardware component.



Note: We recommend fastening a grounding strap to your wrist so that it contacts your bare skin and attaching the other end of the strap to the appliance.

1. Connect to the engine command line. Depending on your appliance type, use one of these options.
 - Connect a keyboard to a USB port and a monitor to the VGA port, then press **Enter**.
 - Connect a computer running a terminal emulator program to the appliance console port, then press **Enter**.



Note: The console port is not enabled by default on 1401 and 1402 appliances.

- Connect using SSH.
2. Enter the logon credentials.
The user name is `root` and the password is the one you set for the appliance.
 3. Enter the command `halt`.
 4. Unplug all power cords from the system or the wall outlets.



Note: SSH access is not enabled by default.

Replace the power supply

The AC power supplies are replaceable.



CAUTION: Do not open the casing of a power supply module. Power supply modules can only be repaired by a qualified technician from the manufacturer.



Note: We recommend fastening a grounding strap to your wrist so that it contacts your bare skin and attaching the other end of the strap to the appliance.

1. Turn off the appliance and disconnect any power cables.
2. Locate the release tab above the power supply module.
3. Push the release tab to the right to release the power supply module from its locking position.
4. Pull out the power supply module using the handle provided.
5. Push the replacement power supply module into the power bay until it clicks in place.

Replace the appliance fans

Replace failed fans to ensure proper cooling of the appliance.

There are four fans on the back panel of the 1402 appliance.

We recommend that you replace all appliance fans at the same time. If one of the fans fails, the other fans might need replacement.



Note: We recommend fastening a grounding strap to your wrist so that it contacts your bare skin and attaching the other end of the strap to the appliance.

1. Turn off the appliance and disconnect any power cables.
2. Press the release tab on the side of the appliance fan to release the fan from its locking position.
3. Remove the fan from the appliance and slide the new fan into the fan housing.

Replace the CFast card

Replace the CFast card with another card that you received from Forcepoint.



Note: We recommend fastening a grounding strap to your wrist so that it contacts your bare skin and attaching the other end of the strap to the appliance.

1. Turn off the appliance and disconnect any power cables.
2. Locate the CFast card on the appropriate panel for your appliance.
 - **321, 325, 1035, and 1065 appliances** — The card is on the back panel.
 - **1401 and 1402 appliances** — The card is on the front panel.
3. Gently push in the CFast card to release the card from the slot.
4. Position the replacement CFast card. Turn the end with the slots toward the appliance. The wider slot must be on the left.
5. Insert the new CFast card into the slot and gently push to lock the card into place.
6. Reconfigure the appliance for the replacement CFast card. See the initial configuration information in the *Stonesoft Next Generation Firewall Installation Guide*.

Replace an interface module

Replace an interface module with the same type or a different type of module.

For 325, 1035, and 1065 appliances, you can replace the interface module with the plate that covered the interface module slot at the time of delivery.

If the number of ports in the old and new module are the same, the mapping between the Interface IDs stays the same. If the number of ports in the new module is different from the old module, or if you replace the module with a placeholder module or a cover plate, you might need to modify the interface definitions.



Note: We recommend fastening a grounding strap to your wrist so that it contacts your bare skin and attaching the other end of the strap to the appliance.

1. Turn off the appliance and disconnect any power cables.
2. Release the module.

- **325 appliances** — Unscrew the thumbscrews and carefully pull the module out of the slot.
 - **1035, 1065, 1401, and 1402 appliances** — Press the release lever, hold it down, and carefully pull the module out of the slot using the handle or the knob on the front panel of the module.
3. Insert the new module.
 4. Connect the cables and plug the power cables to the system and to the wall outlets.
 5. Turn on the appliance.



CAUTION: To ensure proper cooling, do not turn on the appliance if you have not installed an interface module or a placeholder module in each slot. For 325, 1035, and 1065 appliances, you can install the cover plate over the slot instead.

6. If the number of ports in the new module differs from the old module, update the interface configuration.
 1. In the Management Client, modify the interface definitions as needed.
 2. Refresh the policy to transfer the interface changes to the engine.

Remove SFP transceivers

Remove or replace an SFP transceiver.



CAUTION: Invisible laser radiation is emitted from the end of a fiber-optic cable and from the fiber port. Do not stare into the beam and avoid direct exposure to the beam.



Note: We recommend fastening a grounding strap to your wrist so that it contacts your bare skin and attaching the other end of the strap to the appliance.

1. Turn off the appliance and disconnect any power cables.
2. Unplug all power cables from the system or the wall outlets.
3. Disconnect the cable from the SFP transceiver.
4. Pull down the latch on the transceiver and carefully pull the SFP transceiver out of the port slot.
5. If needed, insert a replacement SFP transceiver in the slot.

Reattach the cover plate to the interface module slot

Reattach the module cover plate if there is no module in the slot.



CAUTION: Do not turn on the appliance if a slot is empty or uncovered. Using the appliance without an interface module or the cover plate can damage the appliance and voids the warranty.



Note: We recommend fastening a grounding strap to your wrist so that it contacts your bare skin and attaching the other end of the strap to the appliance.

1. Turn off the appliance.
2. Remove the interface module from the interface module slot.
3. Locate the tab at the lower left corner of the plate.
4. Insert the tab into the hole in the lower left corner of the slot casing.

5. Slide the plate inward until it covers the slot and the thumbscrew in the plate aligns with the screw hole to the right of the slot.
6. Tighten the thumbscrew until the plate is attached firmly in place.

Compliance information

Stonesoft NGFW appliances that have wireless support are in compliance with the EMC directive (2004/108/EC) and the FCC standard (FCC Part 15) for wireless devices intended for home and office use.

This information is valid for all dual band products (2.4 GHz, IEEE 802.11b/g/n, and 5 GHz, IEEE 802.11n).

The supported channels and frequencies for Stonesoft NGFW appliances are listed by country in the Management Client. The wireless configuration is transferred to the appliance when you install the policy on the engine.

Applied technologies

The appliance uses these technologies.

- **Radio spectrum** — Sub-bands 2400–2483,5 MHz, 5150–5250 MHz, 5250–5350 MHz, and 5470–5725 MHz
- **Safety** — Dual band products
- **Electromagnetic Compatibility (EMC)** — Dual band products

National restrictions and requirements for authorization

These appliances can be operated within FCC DFS2 band or ETSI/EC DFS band, or other countries that regulate or plan to regulate mid-5 GHz band.

The usage of mid-5 GHz band is subject to the regulatory approval alone with the resided devices.

The requirements for any country or area might change. We recommend that you check with your local authorities for the latest status of national requirements for 2.4 GHz and 5 GHz wireless LANs.

Find product documentation

On the **ServicePortal**, you can find information about a released product, including product documentation, technical articles, and more.

1. Go to the **ServicePortal** at <https://support.mcafee.com> and click the **Knowledge Center** tab.
2. In the **Knowledge Base** pane under **Content Source**, click **Product Documentation**.
3. Select a product and version, then click **Search** to display a list of documents.

Copyright © 1996 - 2016 Forcepoint LLC
Forcepoint™ is a trademark of Forcepoint LLC.
SureView®, ThreatSeeker®, TRITON®, Sidewinder® and Stonesoft® are registered trademarks of Forcepoint LLC.
Raytheon is a registered trademark of Raytheon Company.
All other trademarks and registered trademarks are property of their respective owners.