



Next Generation Firewall

Models 3201, 3202, 3205, 3206, 3207, 3301,
3305

Hardware Guide

Contents

- Introduction on page 2
- Find product documentation on page 2
- Model 3201 and 3205 features on page 3
- Model 3202 features on page 5
- Model 3206 and 3207 features on page 7
- Model 3301 and 3305 features on page 9
- Indicator lights on page 10
- Ethernet port indicators on page 11
- QSFP+ port indicators on page 12
- SSD indicators on page 12
- Ethernet port names for appliances with interface modules on page 13
- Supported interface modules on page 13
- Precautions on page 21
- Install the appliance on page 22
- Maintenance on page 35

Introduction

Thank you for choosing a Forcepoint appliance.

Familiarize yourself with the appliance ports and indicators and learn how to install the appliance safely.

Find product documentation

On the Forcepoint support website, you can find information about a released product, including product documentation, technical articles, and more.

You can get additional information and support for your product on the Forcepoint support website at <https://support.forcepoint.com>. There, you can access product documentation, release notes, Knowledge Base articles, downloads, cases, and contact information.

You might need to log on to access the Forcepoint support website. If you do not yet have credentials, create a customer account. See <https://support.forcepoint.com/CreateAccount>.

Model 3201 and 3205 features

The figures and tables show the appliance components and features.

Front panel

This panel has the following parts.

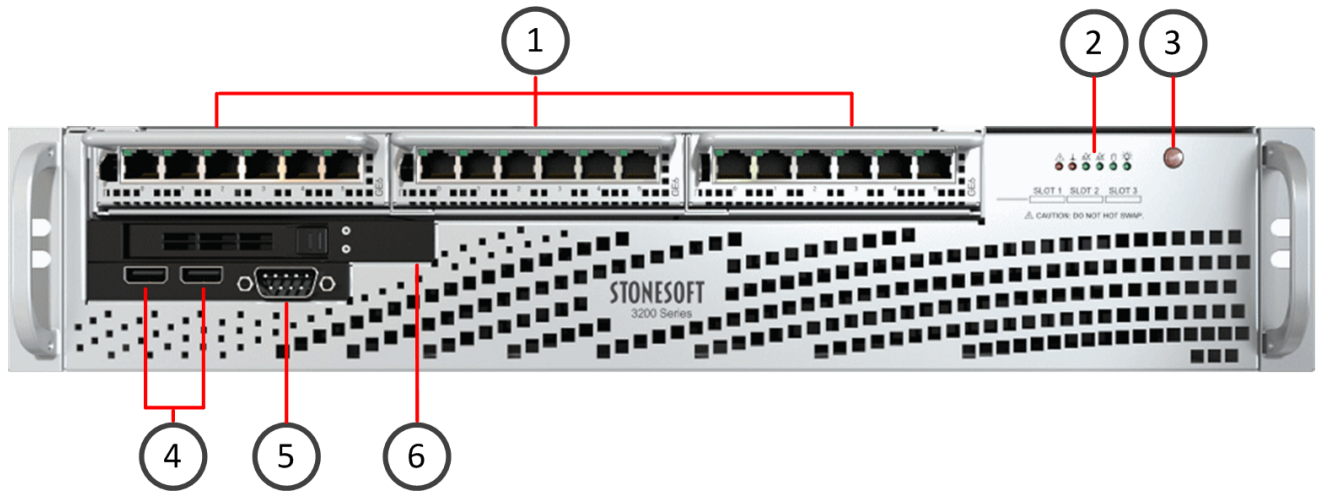

- 1 Interface modules
- 2 Indicator lights
- 3 Power button
- 4 USB ports
- 5 Console port (speed 9600 bps)
- 6 Solid-state drive (SSD)

Back panel

This panel has the following parts.

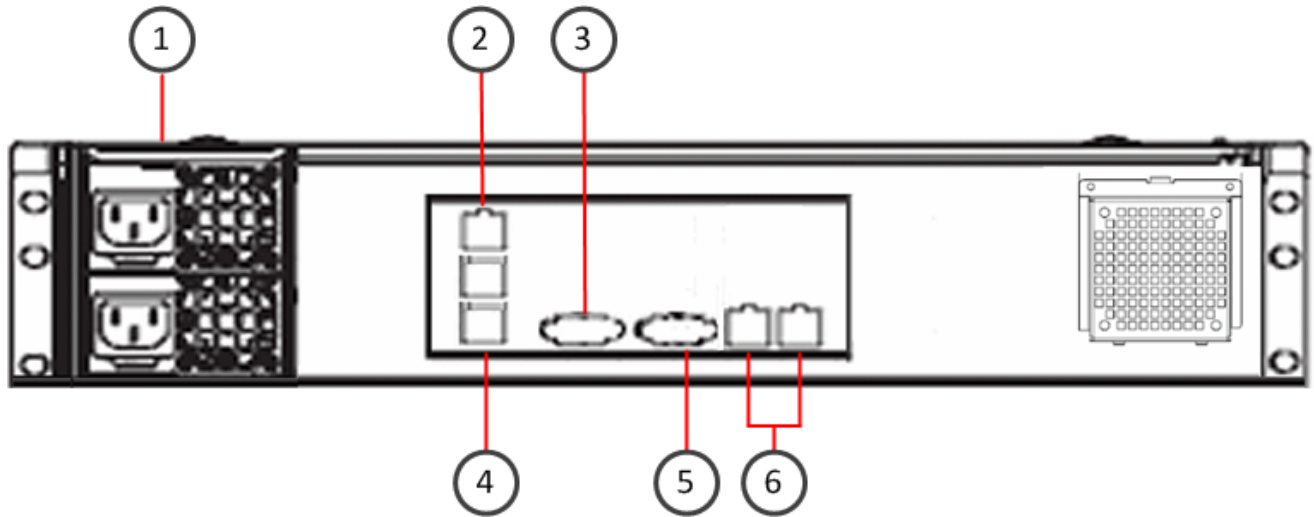

- 1 AC or DC power supplies
- 2 IPMI port (usage not recommended)
- 3 Console port (not used)
- 4 USB ports
- 5 VGA port
- 6 Fixed Ethernet ports

Model 3202 features

The figures and tables show the appliance components and features.

Front panel

This panel has the following parts.

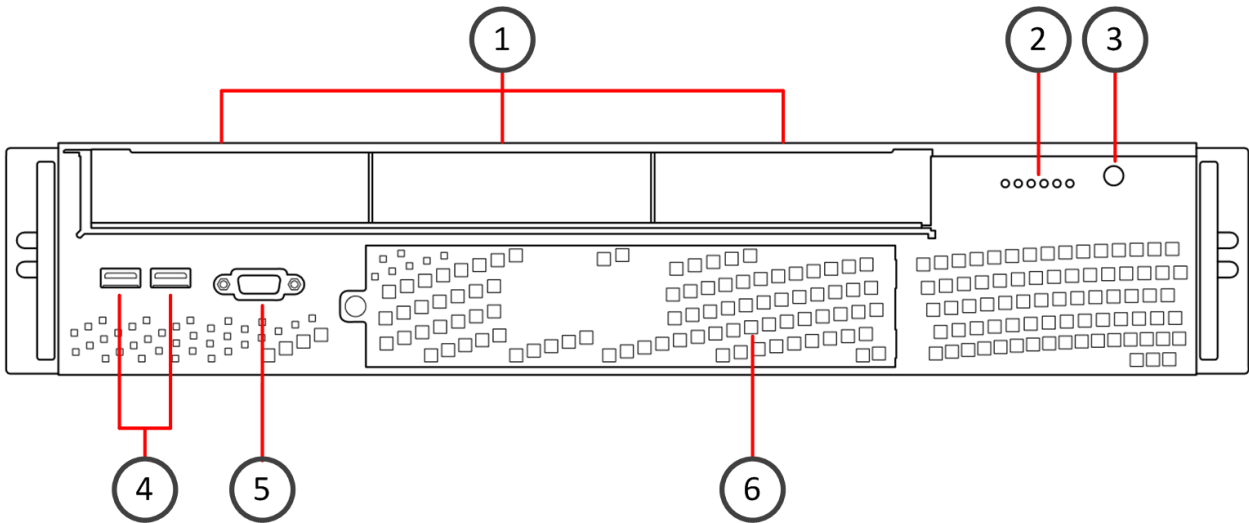

- 1 Interface module slots
- 2 Indicator lights
- 3 Power button
- 4 USB ports
- 5 Console port (primary; speed 9600 bps)
- 6 Fan enclosure plate

Back panel

This panel has the following parts.

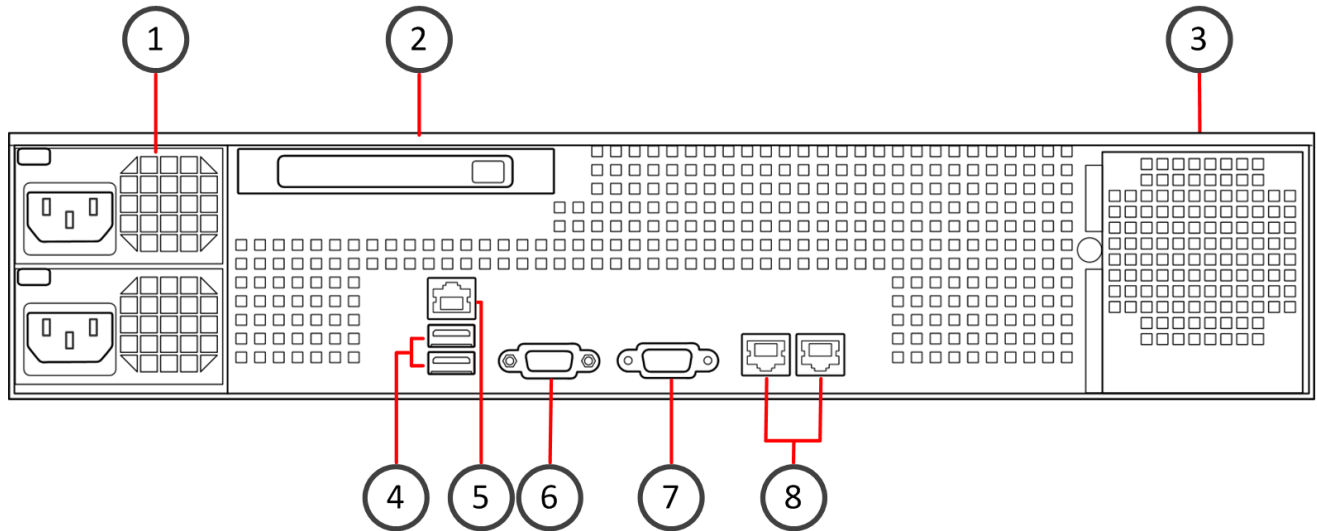

- 1 AC or DC power supplies
- 2 Solid-state drive (SSD)
- 3 Fan enclosure
- 4 USB ports
- 5 IPMI port (usage not recommended)
- 6 Console port (secondary; speed 9600 bps)
- 7 VGA port
- 8 Fixed Ethernet ports

Model 3206 and 3207 features

The figures and tables show the appliance components and features.

Front panel

This panel has the following parts.

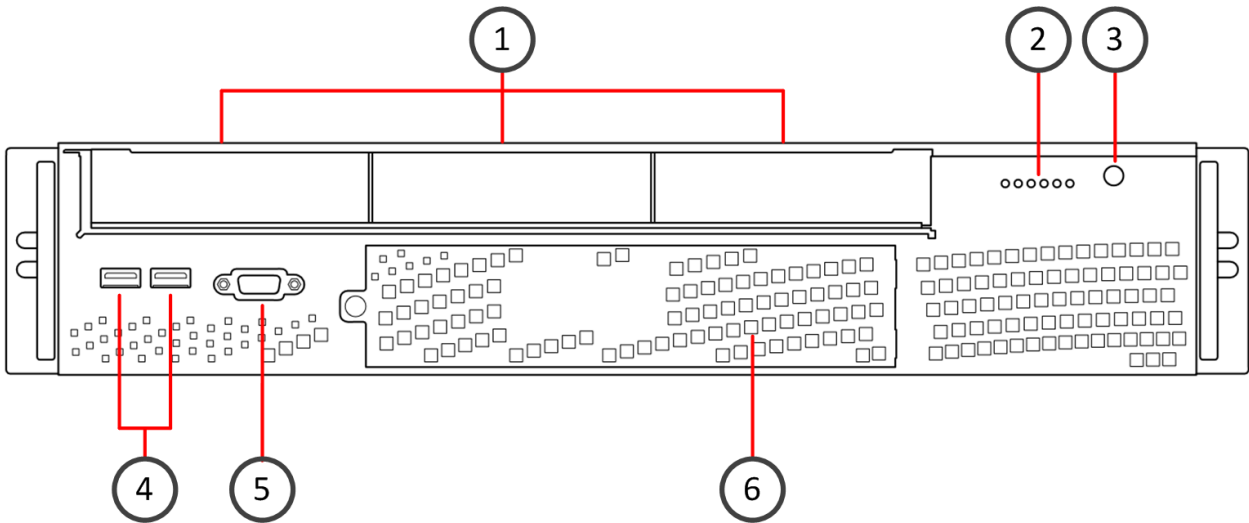

- 1 Interface module slots
- 2 Indicator lights
- 3 Power button
- 4 USB ports
- 5 Console port (primary; speed 9600 bps)
- 6 Fan enclosure plate

Back panel

This panel has the following parts.

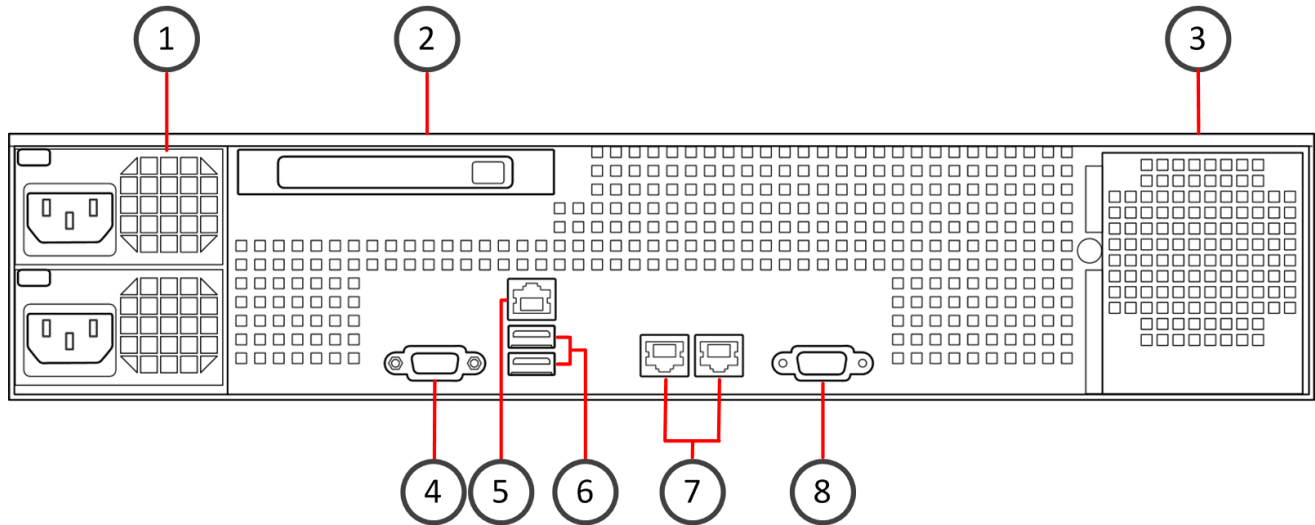

- 1 AC or DC power supplies
- 2 Solid-state drive (SSD)
- 3 Fan enclosure
- 4 Console port (secondary; speed 9600 bps)
- 5 IPMI port (usage not recommended)
- 6 USB ports
- 7 Fixed Ethernet ports
- 8 VGA port

Model 3301 and 3305 features

The figures and tables show the appliance components and features.

Front panel

This panel has the following parts.

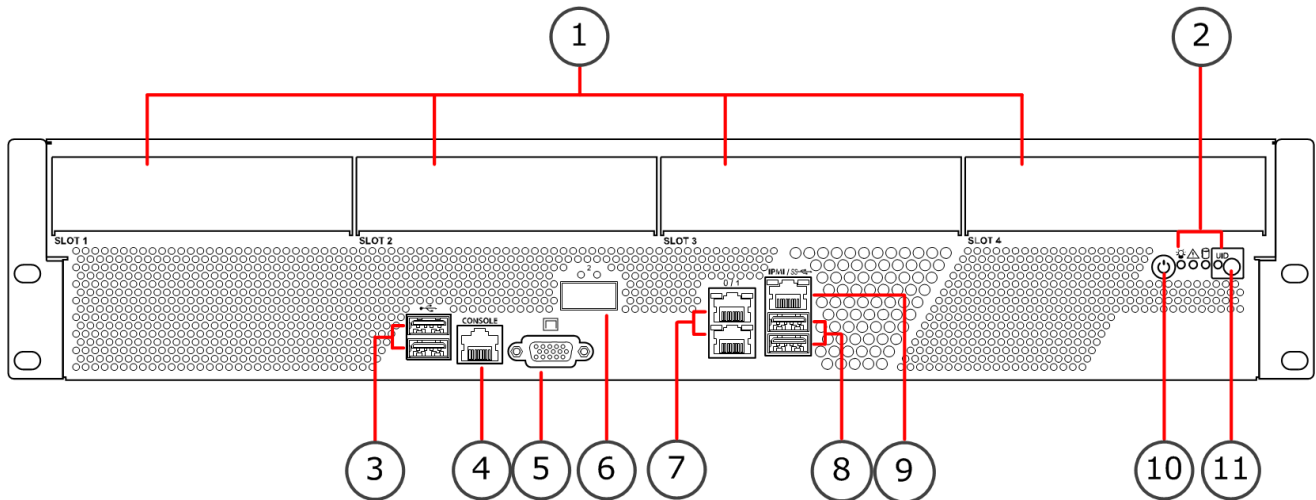

- 1 Interface module slots
- 2 Indicator lights
- 3 USB ports
- 4 Console port (speed 115,200 bps)
- 5 VGA port
- 6 QSFP+ port (3305 appliances only)



Note

You can only use a short-range transceiver in this port.

- 7 Fixed Ethernet ports 0 and 1
- 8 USB ports
- 9 IPMI port (usage not recommended)
- 10 Power button
- 11 UID button

Back panel

This panel has the following parts.

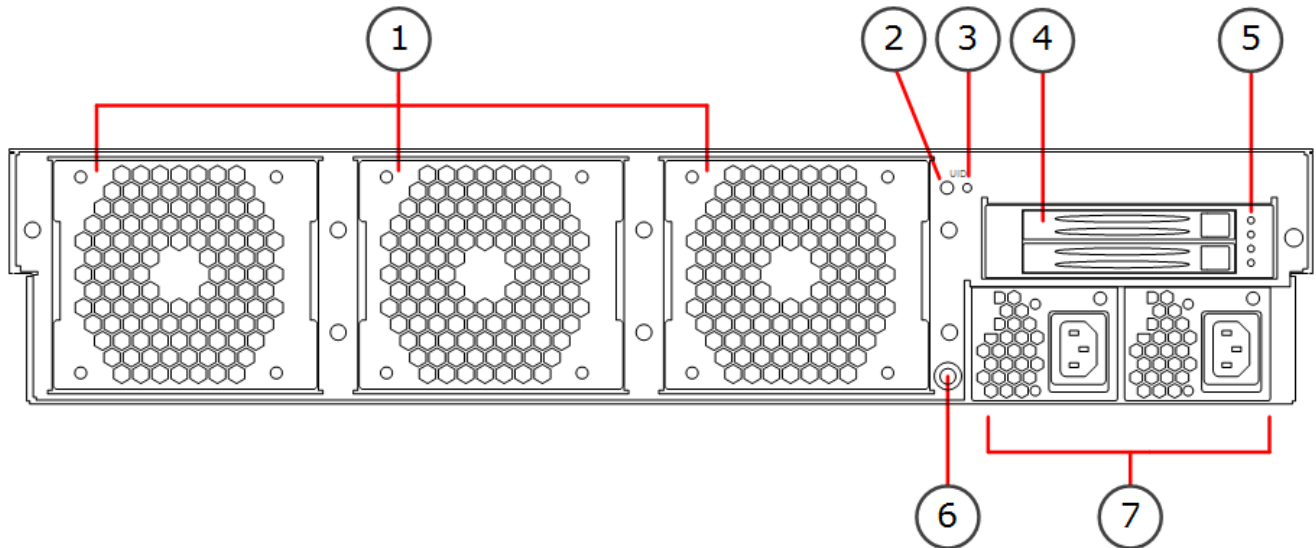



- 1 Fan enclosures
- 2 UID button
- 3 UID indicator
- 4 Solid-state drive (SSD) slots (only the upper slot is used)
- 5 SSD indicators
- 6 Grounding pin
- 7 AC or DC power supplies

Indicator lights



Indicator lights show the status of the appliance and any fixed Ethernet ports.

Models 3201, 3202, 3205, 3206, 3207

Icon	Description
	Indicates that a power supply cable is detached.
	When flashing, indicates a fan failure. When continuously on, indicates an overheat condition, which can be caused by cables obstructing the airflow in the system or the ambient room temperature being too warm.
	When flashing, indicates network activity on the onboard Ethernet interface 1. The interface is on the back panel of the appliance.

Icon	Description
	When flashing, indicates network activity on the onboard Ethernet interface 0. The interface is on the back panel of the appliance.
	When flashing, indicates SSD activity.
	Indicates that power is supplied to the system power supply units. This indicator is illuminated when the system is operating normally.

Models 3301 and 3305

Icon	Indicator	Color	Description
	Power	Green	The appliance is in running state.
		Red	The appliance is in standby state.
	Warning	Red	Overheating. Flashes on fan failure or system failure.
	Disk Activity	Amber	Indicates SSD activity when flashing.
UID	UID	Blue	The UID indicator has been switched on.

Ethernet port indicators

Ethernet port indicators show the status and speed of the network ports.

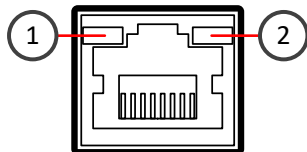

3201, 3205, 3301, and 3305 appliances

- 1 Activity/link indicator
- 2 Link speed indicator

3202, 3206, and 3207 appliances

- 1 Link speed indicator
- 2 Activity/link indicator

Indicator	Color	Explanation
Activity/link indicator	Amber	Link OK, flashes on activity.
Link speed indicator	Unlit	No link. For 3201, 3205, 3206, and 3207 appliances, can indicate a 10 Mbps link.
	Orange	100 Mbps link.
	Green	1 Gbps link.

QSFP+ port indicators

QSFP+ port indicators show the status and speed of the network ports.

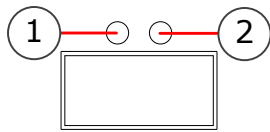

- 1** Activity/link indicator
When amber, the link is OK. Flashes on activity.
- 2** Link speed indicator
When unlit, there is no link.
When green, the link speed is 40 Gbps.

SSD indicators

SSD indicators show the status of the SSDs.

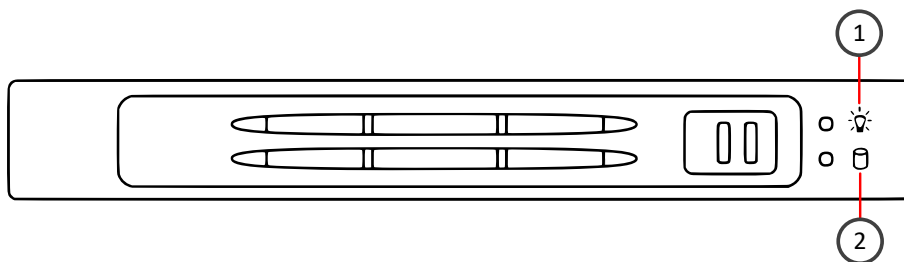

- 1** Power indicator
When lit blue, an SSD is in the slot.
- 2** Disk indicator
This indicator is not used.

Ethernet port names for appliances with interface modules

Ethernet port names are based on the slot and port numbers.

The first number in the name represents the slot on the appliance. The second number represents the port on the slot. For example, eth2_0 is located on port 0 of slot 2.

Models 3201, 3202, 3205, 3206, and 3207

Component	Slot	Location	Port numbers
Fixed Ethernet ports	0	Back panel	eth0_0 and eth0_1.
Interface modules	1–3. The slot numbers for the interface modules start from 1 and increase from left to right.	Front panel	The port numbers start from 0 and increase from left to right. For example, the port farthest to the left in slot 1 is eth1_0.

Models 3301 and 3305

Component	Slot number	Port numbers
Fixed Ethernet ports	0	eth0_0, eth0_1, and (3305 appliances) eth0_2.
Interface modules	1–4. The slot numbers for the interface modules start from 1 and increase from left to right.	The port numbers start from 0 and increase from left to right. For example, the port farthest to the left in slot 1 is eth1_0.

Supported interface modules

Forcepoint NGFW appliances support the following types of interface modules. For a list of all available interface modules and compatibility information, see Knowledge Base article [10245](#).



Note

Do not remove any stickers from modules — they contain important information.

Copper modules

Module	Identifier	Appliance models
2 port 10 gigabit Ethernet RJ45	MO102	3201, 3202, 3205, 3206, 3207, 3301, 3305
2 port 10 gigabit RJ45 bypass	MO102B	3206, 3207
4 port gigabit Ethernet RJ45	MOG4	3206
4 port gigabit Ethernet bypass RJ45	MOG4B	3206, 3207

Module	Identifier	Appliance models
8 port gigabit Ethernet RJ45	MOG8	3201, 3202, 3205, 3206, 3207, 3301, 3305

Fiber modules

Module	Identifier	Appliance models
2 port Fiber bypass LC	MOE2B	3206, 3207
2 port 10 gigabit Ethernet short reach bypass	MO10S2B	3201, 3202, 3205, 3206, 3207, 3301, 3305
2 port 10 gigabit Ethernet long reach bypass	MO10L2B	3201, 3202, 3205, 3206, 3207, 3301, 3305
4 port gigabit Ethernet SX fiber bypass	MOGS4B	3206, 3207

SFP modules

Module	Identifier	Appliance models
2 port 10 gigabit Ethernet SFP+	MO10F2	3201, 3202, 3205, 3206, 3207, 3301, 3305
2 port 40 gigabit Ethernet QSFP	MO40F2	3207, 3301, 3305
4 port gigabit Ethernet SFP	MOGF4	3201, 3202, 3205, 3206, 3207, 3301, 3305
4 port 10 gigabit Ethernet SFP+	MO10F4	3206
4 port 10 gigabit Ethernet SFP+, revision 2	MOE10F4	3207, 3301, 3305

MO102 module

The MO102 module is a two-port 10 gigabit copper interface module.

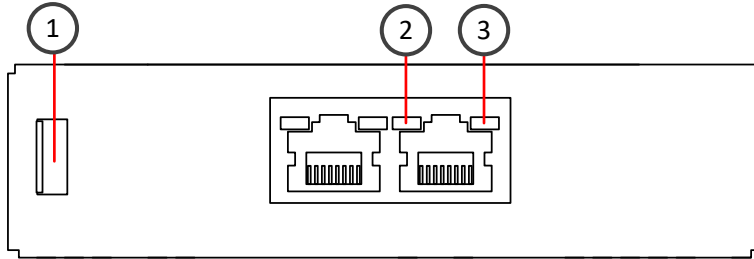

Number	Component	Color	Description
1	Release lever	N/A	N/A
2	Activity/link indicator	Green	Link OK, flashes on activity.
3	Link speed indicator	Yellow	1 Gbps link.
		Green	10 Gbps link.

MO102B module

The MO102B module is a two-port 10 gigabit bypass copper module.

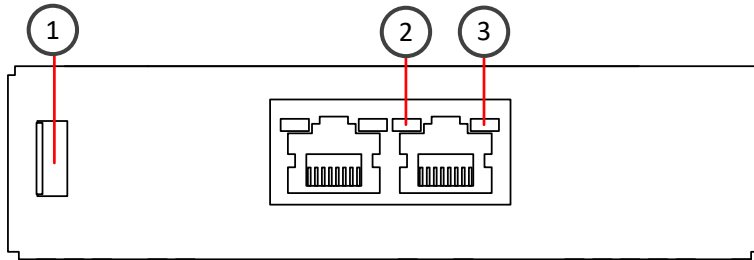

Number	Component	Color	Description
1	Release lever	N/A	N/A
2	Activity/link indicator	Green	Link OK, flashes on activity.
3	Link speed/bypass/disconnect indicator	Amber	1 Gbps link, flashes in disconnect mode.
		Green	10 Gbps link, flashes in bypass mode.

MOG4 module

The MOG4 module is a quad-port gigabit interface module.

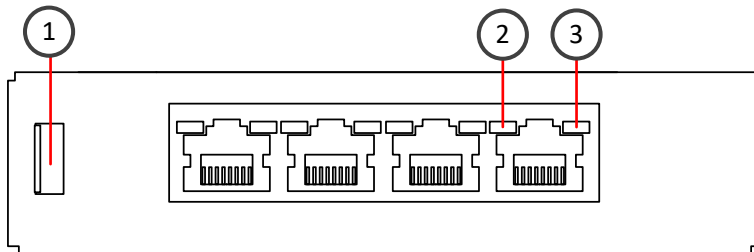

Number	Component	Color	Description
1	Release lever	N/A	N/A
2	Activity/link indicator	Green	Link OK.
3	Link speed indicator	Green	1 Gbps link.
		Amber	100 Mbps link.

MOG4B module

The MOG4B module is a quad-port gigabit bypass copper module.

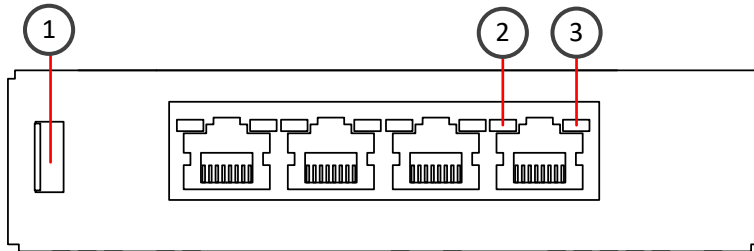

Number	Component	Color	Description
1	Release lever	N/A	N/A
2	Activity/link indicator	Green	Link OK.
3	Link speed/bypass/disconnect indicator	Yellow	1 Gbps link, flashes in disconnect mode.
		Green	100 Mbps link, flashes in bypass mode.
		Unlit	10 Mbps link.

MOG8 module

The MOG8 module is an eight-port gigabit copper interface module.

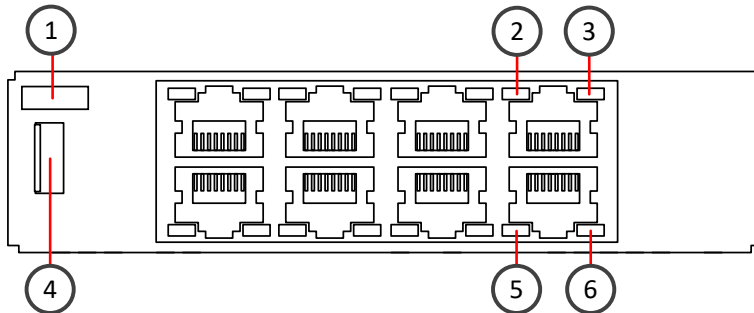

Number	Component	Color	Description
1	Port numbers 0–7	N/A	N/A
2, 5	Activity/link indicator	Green	Link OK, flashes on activity.
3, 6	Link speed indicator	Yellow	1 Gbps link.
		Green	100 Mbps link.
		Unlit	10 Mbps link.
4	Release lever	N/A	N/A

MOE2B module

The MOE2B module is a two-port gigabit bypass fiber module.

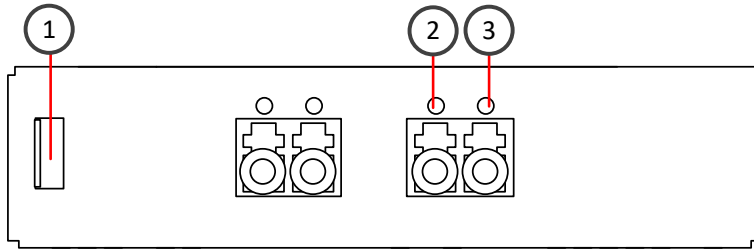

Number	Component	Color	Description
1	Release lever	N/A	N/A
2	Activity/link indicator	Green	Link OK.
3	Link speed/bypass/disconnect indicator	Green	1 Gbps link, flashes in bypass mode.
		Yellow	Flashes in disconnect mode.

MO10S2B module

The MO10S2B module is a two-port 10 gigabit bypass fiber module.

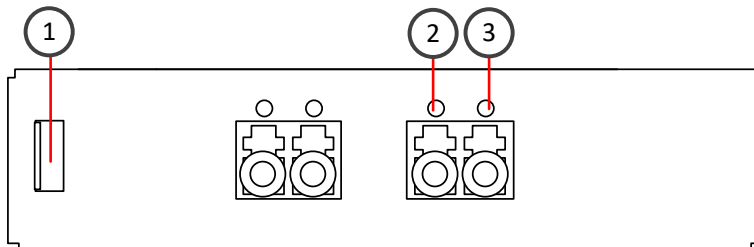

Number	Component	Color	Description
1	Release lever	N/A	N/A
2	Activity/link indicator	Green	Link OK.
3	Link speed/bypass/disconnect indicator	Blue	10 Gbps link.
		Green	Flashes in bypass mode.

MO10L2B module

The MO10L2B module is a two-port 10 gigabit bypass fiber module.

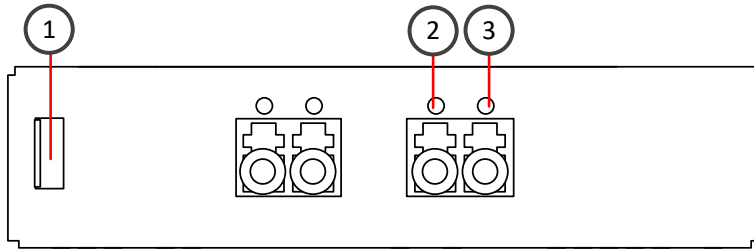

Number	Component	Color	Description
1	Release lever	N/A	N/A
2	Activity/link indicator	Green	Link OK.
3	Link speed/bypass/disconnect indicator	Blue	10 Gbps link.
		Green	Flashes in bypass mode.

MOGS4B module

The MOGS4B module is a quad-port gigabit bypass fiber module.

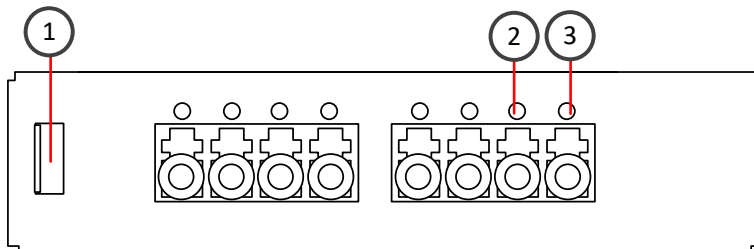

Number	Component	Color	Description
1	Release lever	N/A	N/A
2	Activity/link indicator	Green	Link OK.
3	Link speed/bypass/disconnect indicator	Green	1 Gbps link, flashes in bypass mode.
		Yellow	Flashes in disconnect mode.

MO10F2 module

The MO10F2 module is a two-port 10 gigabit SFP+ interface module.

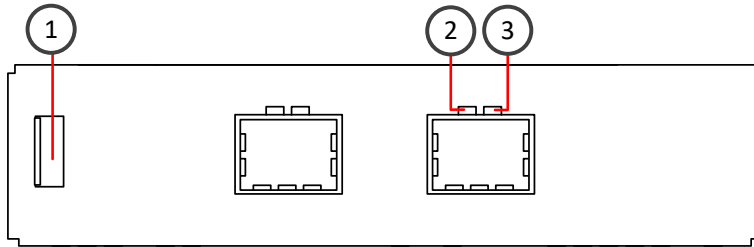

Number	Component	Color	Description
1	Release lever	N/A	N/A
2	Activity/link indicator	Green	Link OK.
3	Link speed indicator	Blue	10 Gbps link.

MO40F2 module

The MO40F2 module is a two-port 40 gigabit QSFP+ interface module.

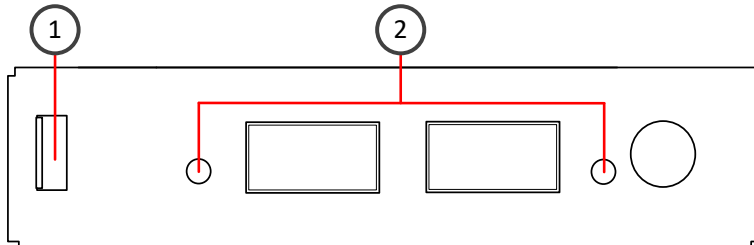

Number	Component	Color	Description
1	Release lever	N/A	N/A
2	Activity/link/link speed indicator	Green	40 Gbps link (other speeds not supported), flashes on activity.

MOGF4 module

The MOGF4 module is a quad-port gigabit SFP interface module.

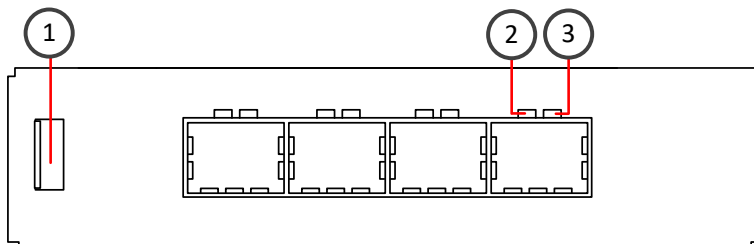

Number	Component	Color	Description
1	Release lever	N/A	N/A
2	Activity/link indicator	Green	Link OK.
3	Link speed indicator	Yellow	1 Gbps link.

MO10F4 module

The MO10F4 module is a quad-port 10 gigabit SFP+ interface module.

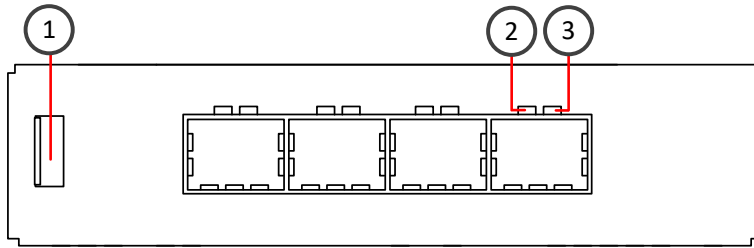

Number	Component	Color	Description
1	Release lever	N/A	N/A
2	Activity/link indicator	Green	Link OK.
3	Link speed indicator	Blue	10 Gbps link.

MOE10F4 module

The MOE10F4 module is a quad-port 10 gigabit SFP+ interface module.

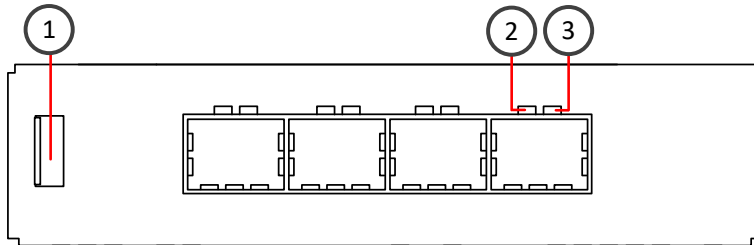

Number	Component	Color	Description
1	Release lever	N/A	N/A
2	Activity/link indicator	Green	Link OK.
3	Link speed indicator	Blue	10 Gbps link.

Precautions

The precautions provide safety guidance when working with Forcepoint appliances and electrical equipment.



CAUTION

Forcepoint appliances cannot be serviced by end users. Never open the appliance covers for any reason. Doing so can lead to serious injury and void the hardware warranty.

For additional safety information, see the *Forcepoint Product Safety and Regulatory Compliance Guide*.

General safety precautions

Read the safety information and follow these rules to ensure general safety whenever you are working with electronic equipment.

- Keep the area around the appliance clean and free of clutter.
- When lifting the appliance, two people at each end should lift slowly with their feet spread out to distribute the weight. Always keep your back straight and lift with your legs.
- Use a regulating uninterruptible power supply (UPS) to keep your system operating during power failures and to protect the appliance from power surges and voltage spikes.
- If you need to turn off or unplug the appliance, always wait at least five seconds before turning on or plugging in the appliance again.

Operating precautions

Follow these precautions when operating the appliance.

- Do not open the power supply casing. Only the manufacturer's qualified technician is allowed to service power supplies.

Electrical safety precautions

Follow basic electrical safety precautions to protect yourself from harm and the appliance from damage.

- Know the locations of the power on/off button and the emergency turn-off switch, disconnection switch, or electrical outlet for the room. If an electrical accident occurs, you can quickly turn off power to the system.
- When working with high-voltage components, do not work alone.
- Turn off the system and disconnect the power before removing or installing system components.
- When working with electrical equipment that is turned on, use only one hand. This is to avoid making a complete circuit, which causes an electric shock. Use extreme caution when using metal tools, which can easily damage any electrical components or circuit boards the tools come into contact with.
- Do not use mats designed to decrease electrostatic discharge as protection from electric shock. Instead, use rubber mats that have been designed as electrical insulators.
- If the power supply cable includes a grounding plug, the plug must be plugged into a grounded electrical outlet.

- Use only the power cable or cables supplied with the appliance.
- If you have to replace the motherboard battery, install it the same way as the original battery. Make sure that the positive side faces up on the motherboard. This battery must be replaced only with the same or an equivalent type recommended by the manufacturer. Dispose of used batteries according to the manufacturer's instructions.
- To avoid injury, do not open the enclosures of power supplies or solid-state drives (SSDs).

**Note**

On appliances that have two power supplies, we recommend that you use both power supplies for redundancy.

AC power supply safety precautions

The appliance power inlet is the disconnect device on the appliance.

DC power supply safety precautions

Follow these precautions for DC power supplies.

- The appliance must be used in a restricted access location and users must be well trained to operate it.
- The outlet for the appliance must be installed near the appliance and be easily accessible.
- The appliance must be protected against electric shock.
- We recommend using a power switch between the appliance and the main power source.
- We recommend using a 30A slow fuse.
- The appliance must have, at minimum, a 12 AWG wire provided for the DC power supply.
- The case of the appliance must be grounded using the power connector pin or the grounding nut. We recommend using both grounding methods.
- The mains supply plug on the power supply cable is the disconnect device on the appliance. To disconnect the appliance, you must first disconnect the mains, then disconnect the ground.

Install the appliance

There are several tasks that must be completed before the appliance is installed.

These tasks and the installation of the appliance might be done by the same person or by different persons:

- The Security Management Center (SMC) administrator is responsible for the tasks that are needed before the appliance is installed.
- The on-site installer is responsible for installing the appliance.

For more information, see the *Forcepoint Next Generation Firewall Installation Guide*.

To prepare for the appliance installation, the SMC administrator must do the following:

- 1) If the SMC has not yet been installed, install the SMC.

**Important**

Do not install the SMC on the NGFW appliance.

The SMC can manage many NGFW appliances.

- 2) In the Management Client component of the SMC, create and configure the NGFW Engine element that represents the appliance.
- 3) In the Management Client component of the SMC, save the initial configuration.
The SMC administrator must either:
 - Upload the initial configuration to the Installation Server for plug-and-play configuration of the appliance.



Note

There are additional requirements for plug-and-play configuration. See Knowledge Base article [9662](#).

- Give the on-site installer a USB drive that contains an initial configuration file for each appliance.

The on-site installer must do the following:

- 1) Inspect the appliance, delivery box, and all components included in the shipment.



Important

Do not use damaged appliances or components.

- 2) Connect all necessary power and network cables and other components, then turn on the appliance. If the plug-and-play configuration method is not used, the on-site installer must use the USB drive that contains the initial configuration files to configure the NGFW Engine software.
- 3) When you have finished installing the appliance, inform the SMC administrator so that the administrator can check the status of the appliance in the Management Client.

Rack-mount the appliance

The rack-mounting procedure varies depending on the type of rack unit. If needed, see the documentation for your rack unit.



Important

Read the safety precautions before you rack-mount the appliance. Do not install the appliance upside down.



Note

The long brackets used for the four-post installation of a 3301 or 3305 appliance must be ordered separately.

Determine the placement of each component in the rack.

- Install the heaviest components on the bottom of the rack first. Install components from the bottom to the top.
- The appliance must be connected to a grounded power outlet.

- Use a UPS to protect the appliance from power surges and voltage spikes, and to keep your system operating if there is a power failure.
- To maintain proper cooling, always keep the front door of the rack and all panels and components on the appliances closed when not servicing.

Related concepts

[General safety precautions](#) on page 21

Install a 3201, 3202, 3205, 3206, or 3207 appliance in a two-post rack

Use the rack-mounting brackets to secure the appliance in the rack.

Steps

- 1) Locate the two rack-mounting brackets for the two-post rack installation.

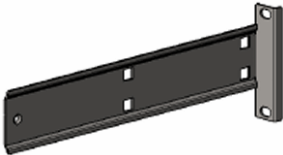

- 2) Locate the three pairs of supports on the side of the appliance and the corresponding holes on the brackets.
- 3) Align the holes against the two supports toward the rear of the appliance and push the bracket under the supports.

The brackets are marked with "L" for left and "R" for right.

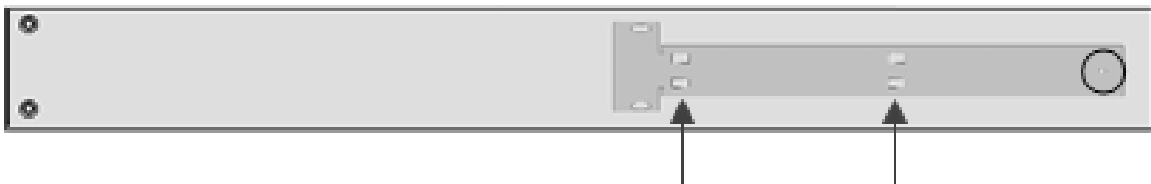

- 4) Secure the bracket to the appliance by inserting a screw through the hole at the end of the bracket.
- 5) Attach a bracket to the other side of the appliance.
- 6) Attach each bracket to the rack with two screws through the holes in the front of the bracket.

Install a 3301 or 3305 appliance in a two-post rack

Use the rack-mounting brackets to secure the appliance in the rack.

Steps

- 1) Locate the rack-mounting brackets for the two-post rack installation.

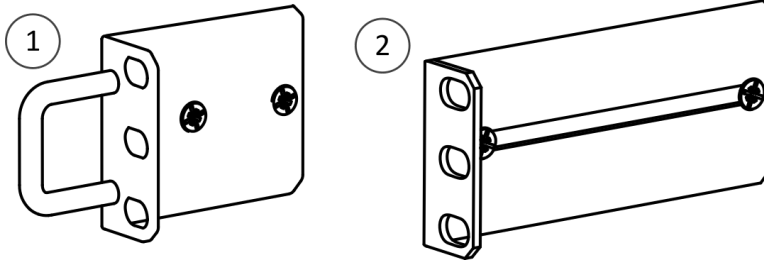

- 1 (Usage optional) Two brackets that attach to the front panel of the appliance.
- 2 Two brackets for attaching the appliance to the post.

- 2) Attach a bracket to each side of the appliance with two screws through the grooves in the bracket.

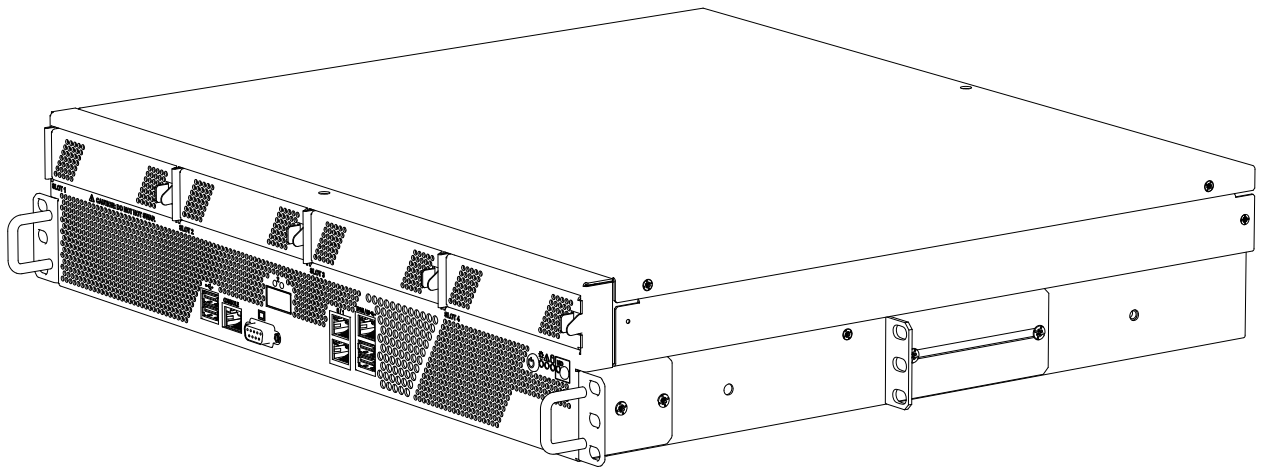

- 3) Attach the brackets to the rack with three screws through the holes in the front of the brackets: one screw through the top hole, the second through the middle hole, and the third through the bottom hole.

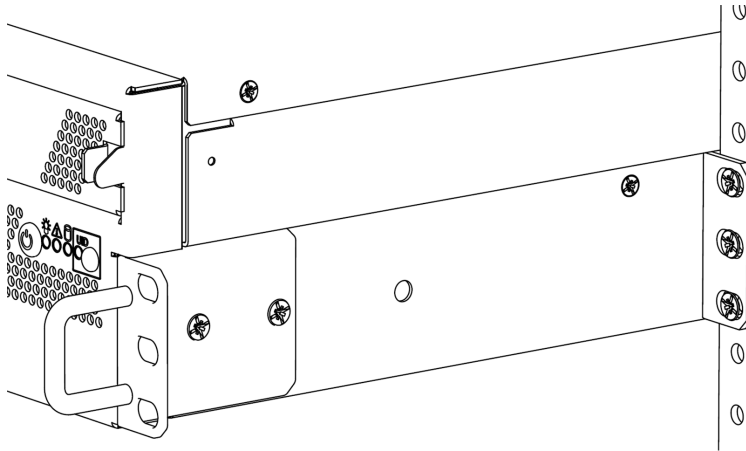
**CAUTION**

Use all three screws to attach each rack-mounting bracket to the rack. Using fewer screws might not provide sufficient support and can damage the appliance.

Install a 3201, 3202, 3205, 3206, or 3207 appliance in a four-post rack

Use the rack-mounting brackets to secure the appliance in the rack.

Use rail sets of these lengths for installing the appliance in the rack.

- 19–26.6 in. or 48.26–67.56 cm
- 26.5–36.4 in. or 67.31–92.46 cm

Steps

- 1) Locate the two pairs of brackets, two inner rails that attach to the appliance, and two outer rails that attach to the rack.
The rails are marked with "L" for left and "R" for right.

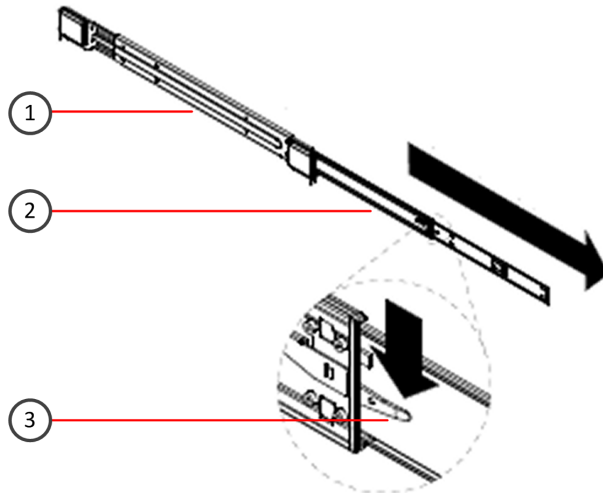

- 1 Outer rail
- 2 Inner rail
- 3 Locking tab

- 2) Detach the inner rails from the outer rails by pressing the locking tab to release the inner rails.
- 3) Locate the rail buttons on the side of the appliance and the corresponding holes on an inner rail.
- 4) Align the holes against the corresponding buttons. When all are aligned, push the holes toward the corresponding buttons.

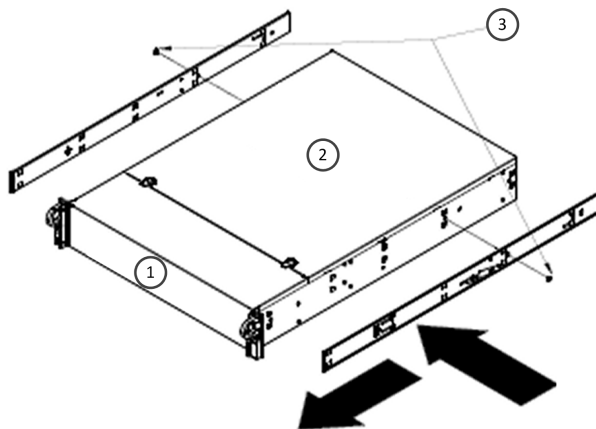

- 1 Front of appliance
- 2 Top of appliance
- 3 Screws

- 5) Secure the rail to the appliance with a screw.

- 6) Attach the second inner rail to the other side of the appliance.
- 7) Insert the outer rails to the rack.
If necessary, push the locking tab on the rail to pull out the outer rails.

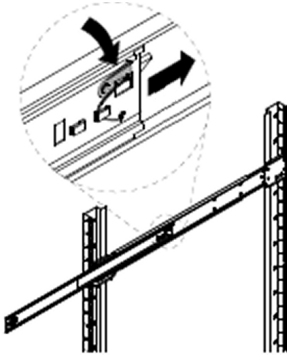

- 8) Attach the outer rails to the rack with two screws through the holes at the ends of the rails.
- 9) Line up the rear of the inner rails with the front of the extended outer rails.

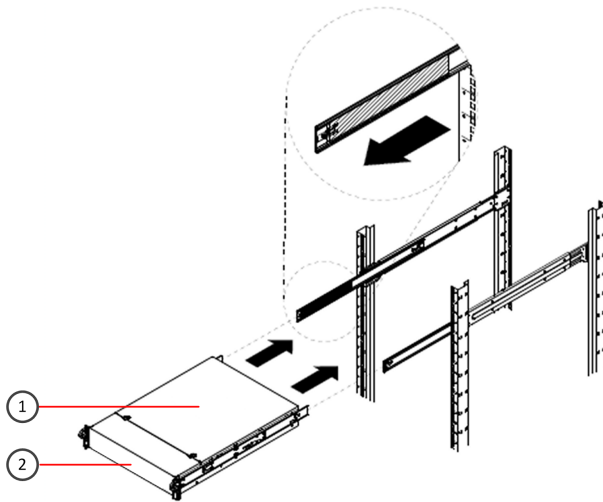

- 1 Top of appliance
- 2 Front of appliance

- 10) Slide the inner rails into the outer rails, keeping the pressure even on both sides.



Tip

You might have to press the locking tabs when inserting the rails.

When the appliance is pushed completely into the rack, the locking tabs click as the rails lock.

Install a 3301 or 3305 appliance in a four-post rack

Use the rack-mounting brackets to secure the appliance in the rack.

Use bracket sets of these lengths for installing the appliance in the rack.

- medium-length brackets: 15.59–25.59 in. or 39.6–65 cm
- long brackets: 25.59–35.43 in or 65–90 cm



Note

The long brackets must be ordered separately.

Steps

- 1) Locate the two pairs of brackets in the delivery package: two short brackets that attach to the appliance and two longer brackets that attach to the rack.

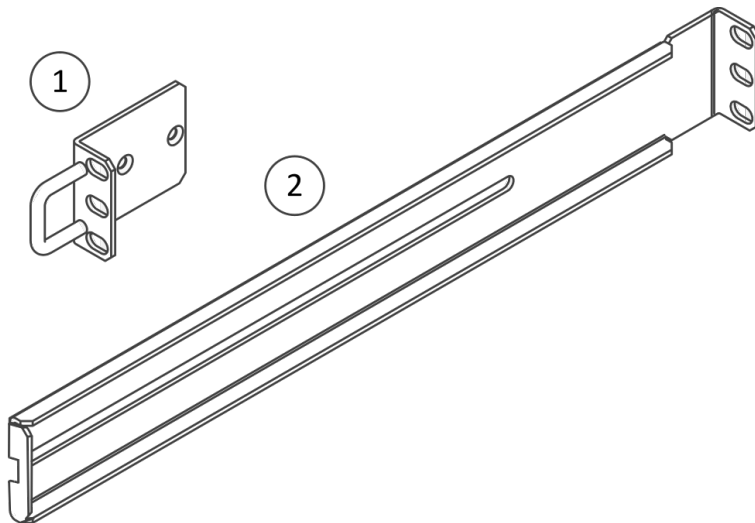

- 1 Short bracket (attaches to the appliance)
- 2 Longer bracket (attaches to the rack)

- 2) Attach a short bracket to both sides of the appliance using two screws for each bracket.

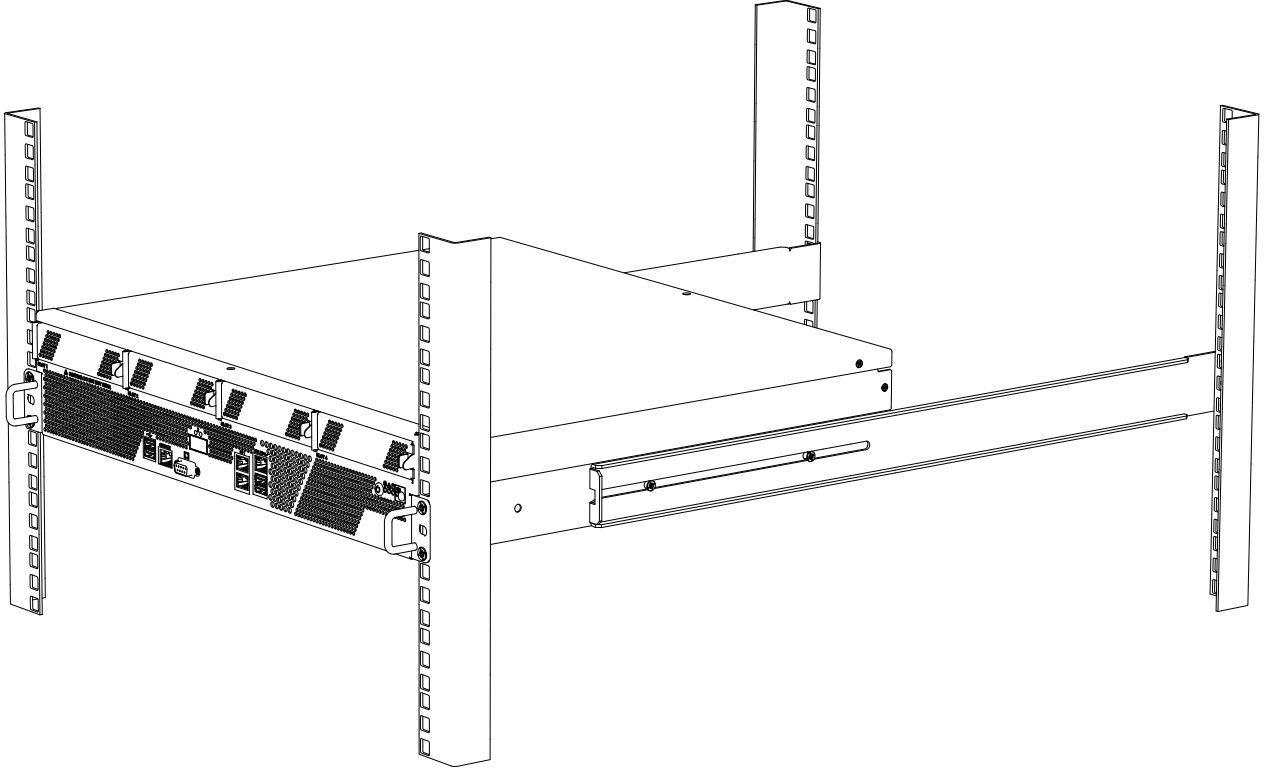

- 3) Attach the two longer brackets to the back of the rack with three screws through the holes at the back of each bracket: one screw through the top hole, another through the middle hole, and the third through the bottom hole.

**CAUTION**

Use all three screws to attach each rack-mounting bracket to the rack. Using fewer screws might not provide sufficient support and can damage the appliance.

- 4) Attach two or three screws with a wider head to a suitable position on the side of the appliance. Do the same for the other side of the appliance.

**Note**

These screws support the appliance when it is inserted into the rack. The number and position of the screws depends on the depth of the rack.

- 5) Line up the screws that you have attached to the appliance with the groove in the brackets attached to the rack.
- 6) Slide the appliance into the brackets in the rack.

- 7) Attach the appliance to the rack with three screws through the holes in the front of the short brackets: one screw through the top hole, the second through the middle hole, and the third through the bottom hole.

**CAUTION**

Use all three screws to attach each rack-mounting bracket to the rack. Using fewer screws might not provide sufficient support and can damage the appliance.

Install the SSD

Install the SSD if it is not already installed.

The SSD slot is on the front panel of 3201 and 3205 appliances, and on the back panel of 3202, 3206, 3207, 3301, and 3305 appliances. On the 3301 and 3305 appliances, use only the upper slot.

**Note**

We recommend fastening a grounding strap to your wrist so that it contacts your bare skin and attaching the other end of the strap to the appliance.

**CAUTION**

Uninstalled SSDs are sensitive to damage from electrostatic discharge.

Steps

- 1) Press the release button on the SSD to release the lever.
- 2) Insert the SSD into the slot.

**Important**

Use only the upper SSD slot on 3301 and 3305 appliances.

- 3) Push the lever down to lock the SSD into position.

Install an interface module

If you have interface modules, install them in the appliance.

Before you begin

Read the safety precautions and make sure any interface modules you install are the correct type for your appliance.

**CAUTION**

To avoid damaging the modules or the appliance, do not install or remove any interface modules if the appliance is turned on.

**Note**

We recommend fastening a grounding strap to your wrist so that it contacts your bare skin and attaching the other end of the strap to the appliance.

Steps

1) Locate the slot to install the module in.

2) Push the module into the slot.

The module is seated correctly when the front panel of the module is even with the front panel of the appliance.

**Note**

If the module has a sticker, make sure that the sticker faces up.

**Important**

Do not insert the module in the wrong orientation. Inserting the modules incorrectly might damage the appliance and the modules and voids the warranty.

Related concepts

[General safety precautions](#) on page 21

Connect the cables

Connect the network and power cables.

**CAUTION**

On appliances that have an Intelligent Platform Management Interface (IPMI) port, the IPMI port is disabled by default. We do not recommend that you enable the IPMI port and connect a cable to it. This might help an unauthorized user to find a way to access and manage the appliance remotely and compromise the security of the system.

Use at least CAT5e-rated cables for gigabit networks. Always use standard cabling methods. Use crossover cables to connect the appliance to hosts and straight cables to connect the appliance to switches or hubs. For more information, see the *Forcepoint Next Generation Firewall Installation Guide*.

Network interfaces at both ends of each cable must have identical speed and duplex settings. These settings include the automatic negotiation setting. If one end of the cable uses autonegotiation, the other end must also use autonegotiation. Gigabit standards require interfaces to use autonegotiation. Fixed settings are not allowed at gigabit speeds.

The settings for inline interfaces must be identical for all four interfaces. The pair on the appliance and the interfaces on the two devices connecting to the appliance must have the same speed and duplex settings configured.

Ethernet port mapping

For appliances that have removable interface modules, Ethernet port names are based on the slot and port numbers.

The first number in the name represents the slot on the appliance, and the second number represents the port on the slot. For example, eth2_0 is located on port 0 of slot 2.

- Slot 0 contains the fixed Ethernet ports.
- Slots 1 and higher contain the ports on the interface modules.
The port numbers start at 0 and increase from left to right.

During the initial configuration of the appliance, you map the Ethernet ports to the interface IDs that you defined in the Management Client.

The NGFW Configuration Wizard shows the mapping between the interface IDs and port names. In the command line version of the NGFW Configuration Wizard, Interface IDs appear in the **ID** column and port names appear in the **Name** column.

This mapping can change if you replace an interface module. If the new module has more Ethernet ports, the interface IDs for the new ports start from the next free interface ID number.

Example: You have thirteen interfaces numbered 0–12, which includes a four-port module installed in slot 1. If you replace the four-port module installed in slot 1 with a two-port module, eth1_2 with ID 10 and eth1_3 with ID 11 are removed.

Example before and after ID mapping

ID	Name	Driver
	modem0	
0	eth0_0	igb
1	eth0_1	igb
2	eth0_2	igb
3	eth0_3	igb
4	eth0_4	ixgbe
5	eth0_5	ixgbe
6	eth0_6	ixgbe
7	eth0_7	ixgbe
8	eth1_0	igb
9	eth1_1	igb
10	eth1_2	igb
11	eth1_3	igb
12	wlan0	ath10k_pci
	<Add..>	<Autod



ID	Name	Driver
	modem0	
0	eth0_0	igb
1	eth0_1	igb
2	eth0_2	igb
3	eth0_3	igb
4	eth0_4	ixgbe
5	eth0_5	ixgbe
6	eth0_6	ixgbe
7	eth0_7	ixgbe
8	eth1_0	igb
9	eth1_1	igb
12	wlan0	ath10k_pci
	<Add..>	<Add..>

Connect network and management cables

Connect the appliance to your networks. The management connection allows you to view the system console.



Note

Ethernet ports are mapped to interface IDs during the initial configuration. The ports and port numbers of the physical appliance must match the interface definitions and interface IDs configured for the engine in the Management Client.

Steps

- 1) Determine which Ethernet ports to use and connect the ports to your networks.

- 2) Select one of these options for the management connection depending on the appliance model and features:
 - Connect a null-modem cable to the console port of the appliance and to another computer for a terminal connection.
 - Connect a monitor to the VGA port and a keyboard to a USB port.

**Note**

The serial console is not enabled by default on some appliances and cannot be used for the initial configuration. To use the serial console after the initial configuration on these appliances, use the command `sg-bootconfig` on the NGFW Engine command line. For more information, see *Command line tools* in the *Forcepoint Next Generation Firewall Product Guide*.

Connect network cables to SFP ports

If you installed an SFP interface module on the appliance or the appliance has an integrated SFP port, insert the copper or fiber-optic SFP transceiver into the port, then connect the cables.

Steps

- 1) Insert the SFP transceiver in the port slot until you feel the connector on the transceiver snap into place.

**Note**

Make sure that the latch on the SFP transceiver is up when you insert the SFP transceiver in the port slot.

- 2) If the SFP transceiver has a rubber plug, remove the plug.
- 3) Connect the copper or fiber-optic cable to the SFP transceiver.

**Note**

Each SFP port must match the wavelength specifications at the other end of the cable. The cable must not exceed the stipulated cable length for reliable communications.

Connect the power supplies

Connect power cables to the power supplies on the back of the appliance.

Before you begin

See the safety precautions topic for information about power supplies.

We highly recommend the following configurations.

- On appliances that have two power supply modules for redundant power sources, connect both power supplies to a power source. This ensures that the appliance can function if one of the power connections fails.

- Use a UPS to ensure continuous operation and minimize the risk of damage to the appliance in case of sudden loss of power. For a truly redundant power supply, connect each power connector on the appliance to a different UPS, so that the failure of one UPS does not cut power to both power supplies.



Note

Standby power is supplied to the system even when the appliance is turned off.

Steps

- 1) Connect the power cables to the power connectors on the back of the appliance.
- 2) Plug the power cable into a grounded, high-quality power strip that offers protection from electrical noise and power surges.

Related concepts

[General safety precautions](#) on page 21

Maintenance

Forcepoint NGFW appliances ship with replaceable components.

Turn off the appliance

Most Forcepoint NGFW appliance hardware components are not hot-swappable. Turn off the appliance from the NGFW Engine command line.

The only hot-swappable components are power supplies, and the 3202, 3206, 3207, 3301, and 3305 appliance fans. Turn off the appliance and disconnect power before replacing other hardware components.



Tip

The SMC administrator can also turn off the appliance remotely using the Management Client. For more information, see the *Forcepoint Next Generation Firewall Product Guide*.

Steps

- 1) Connect to the NGFW Engine command line.
Depending on the appliance type, use one of the following options:
 - Connect a keyboard to a USB port and a monitor to the VGA port, then press **Enter**.
 - Connect a computer running a terminal emulator program to the appliance console port, then press **Enter**.
 - Connect using SSH.



Note

SSH access is not enabled by default.

- 2) Enter the logon credentials.

The user name is `root` and the password is the one you set for the appliance.

- 3) Enter the following command:

```
halt
```

- 4) Wait until the power indicator light turns red or is unlit, then unplug all power cables from the appliance.

Replace the power supply

The power supplies are replaceable on most Forcepoint NGFW appliances. If both power supplies are connected to a power source, the power supplies are hot-swappable.



CAUTION

You can only hot-swap a power supply if both power supplies are AC power supplies or both power supplies are DC power supplies.



CAUTION

Do not open the casing of a power supply module. Power supply modules can only be repaired by a qualified technician from the manufacturer.



Note

We recommend fastening a grounding strap to your wrist so that it contacts your bare skin and attaching the other end of the strap to the appliance.

Steps

- 1) Unplug the power cable from the AC power supply module or disconnect the wires from the DC power supply module.
- 2) Locate the release tab on the left side of the power supply.
- 3) Push the release tab to the right to release the power supply module from the locking position.
- 4) Pull out the power supply module using the handle provided.
- 5) Push the replacement power supply module into the power slot until it clicks in place.

Replace the appliance fans

Replace failed fans to ensure proper cooling of the appliance.

There are four front fans and one back fan on 3202, 3206, and 3207 appliances. There are three back fans on 3301 and 3305 appliances.

The fans are hot-swappable. We recommend that you replace all appliance fans if one of the fans fails.



CAUTION

Do not remove all fans at the same time if the appliance is running.



CAUTION

Keep your fingers away from moving fan blades. When you are inserting a fan, the fan begins spinning as soon as it is connected to the power connector.



Note

We recommend fastening a grounding strap to your wrist so that it contacts your bare skin and attaching the other end of the strap to the appliance.

Replace the front fans on 3206 and 3207 appliances

Access the front fans from the fan enclosure plate on the front panel.

Steps

- 1) Unscrew and remove the fan enclosure plate.
- 2) Grasp the fan by the handles on the front of the fan and pull the fan carefully out of the slot.
- 3) Align the replacement fan with the guides so that the power connector on the fan aligns with the power connector on the appliance.
- 4) Slide the fan into the slot and press gently to connect the fan to the power connector.
The fan should fit securely in the slot. If the fan is loose, it is not inserted correctly.



CAUTION

Do not use excessive force when reinserting fans. Doing so can damage or misalign the power connector.

- 5) Reattach the fan enclosure plate.

Replace the back fan on 3201, 3206, and 3207 appliances

Access the back fan from the fan enclosure on the back panel.

Steps

- 1) Unscrew the fan enclosure.
- 2) Pull the fan enclosure carefully out of the slot.
- 3) Align the power connector on the fan with the power connector on the appliance.
- 4) Slide the replacement fan enclosure into the slot and press gently to connect the fan to the power connector.



CAUTION

Do not use excessive force when reinserting fans. Doing so can damage or misalign the power connector.

- 5) Secure the screw.

Replace the fans on 3301 and 3305 appliances

Replace failed fans to ensure proper cooling of the appliance.

Steps

- 1) Press the release tabs on the side of the appliance fan to release the fan from its locking position.
- 2) Remove the fan from the appliance, then slide the new fan into the fan housing.

Replace the SSD

Replace an SSD with another of the same model.

The SSD slot is on the front panel of 3201 and 3205 appliances, and on the back panel of 3202, 3206, 3207, 3301, and 3305 appliances. On the 3301 and 3305 appliances, use only the upper slot.



Note

We recommend fastening a grounding strap to your wrist so that it contacts your bare skin and attaching the other end of the strap to the appliance.



CAUTION

Uninstalled SSDs are sensitive to damage from electrostatic discharge.

Steps

- 1) Turn off the appliance and disconnect any power cables.
- 2) Press the release button to release the lever that locks the SSD into position.
- 3) Pull the lever carefully, then remove the SSD from the slot.
- 4) Remove the SSD from the tray, then insert the new SSD into the tray.
- 5) Press the release button on the new SSD to release the lever.
- 6) Insert the SSD into the same slot as the SSD that you removed.



Important

Use only the upper SSD slot on 3301 and 3305 appliances.

- 7) Push the lever down to lock the SSD into position.

Replace an interface module

Replace an interface module with the same type or a different type of module.



Note

We recommend fastening a grounding strap to your wrist so that it contacts your bare skin and attaching the other end of the strap to the appliance.

Steps

- 1) Turn off the appliance and disconnect any power cables.
- 2) Release the module from its locking position by pressing and holding the lever right, then pulling the module carefully out of the slot using the handle or the knob on the module's front panel.



Note

If the unlocked module does not move, keep the release lever to the right, press the module gently toward the back of the slot, and pull the module again by the handle or the knob.

- 3) Insert the new module.
- 4) Connect the cables and plug the power cables to the system and to the wall outlets.

- 5) Turn on the appliance.

**CAUTION**

To ensure proper cooling, do not turn on the appliance if you have not installed an interface module or a placeholder module in each slot.

- 6) Update the interface configuration.

- a) On the command line of the NGFW Engine, enter the following command to start the NGFW Configuration Wizard:

```
sg-reconfigure
```

- b) In the network interface configuration options, make sure that the autodetected information is correct and that all interfaces have been detected.
If autodetection fails, add network drivers manually. For detailed instructions, see the *Forcepoint Next Generation Firewall Installation Guide*.
- c) If the number of ports in the new module differs from the old module, adjust the mapping of interfaces to interface IDs.

**CAUTION**

Do not select the **Clear** action when modifying interface IDs in the NGFW Configuration Wizard on the command line. Selecting **Clear** removes all mapping information between interface IDs and Ethernet ports, and restores the default values.

- d) On the **Prepare for Management Contact** page, highlight **Finish**, then press **Enter**.
- e) If the number of ports in the new module differs from the old module, modify the interface definitions in the Management Client, then refresh the policy to transfer the interface changes to the engine.
Make sure to use the same interface IDs that you mapped to the interfaces in the NGFW Configuration Wizard for the interface definitions in the Management Client.

Related concepts

[Ethernet port mapping](#) on page 33

Remove SFP transceivers

You can remove or replace SFP transceivers.

**CAUTION**

Invisible laser radiation is emitted from the end of a fiber-optic cable and from the fiber port. Do not stare into the beam and avoid direct exposure to the beam.



Note

We recommend fastening a grounding strap to your wrist so that it contacts your bare skin and attaching the other end of the strap to the appliance.

Steps

- 1) Turn off the appliance and disconnect any power cables.
- 2) Unplug all power cables from the system or the wall outlets.
- 3) Disconnect the cable from the SFP transceiver.
- 4) Pull down the latch on the transceiver, then carefully pull the SFP transceiver out of the port slot.
- 5) If needed, insert a replacement SFP transceiver in the slot.

Related tasks

[Connect network cables to SFP ports on page 34](#)

