



Next Generation Firewall

Model 3510

3500 Series

Hardware Guide

Contents

- Introduction on page 2
- Find product documentation on page 2
- Series 3510 features on page 3
- Indicator lights on page 4
- Ethernet port indicators on page 5
- SSD indicators on page 6
- Ethernet port names for appliances with interface modules on page 6
- Supported interface modules on page 6
- LCD display on page 18
- Precautions on page 19
- Install the appliance on page 21
- Maintenance on page 32

Introduction

Thank you for choosing a Forcepoint appliance.

Familiarize yourself with the appliance ports and indicators and learn how to install the appliance safely.

Find product documentation

In the Forcepoint Customer Hub, you can find information about a released product, including product documentation, technical articles, and more.

You can get additional information and support for your product in the Forcepoint Customer Hub at <https://support.forcepoint.com>. There, you can access product documentation, release notes, Knowledge Base articles, downloads, cases, and contact information.

You might need to log on to access the Forcepoint Customer Hub. If you do not yet have credentials, create a customer account. See <https://support.forcepoint.com/CreateAccount>.

Series 3510 features

The figures and tables show the appliance components and features.

Front panel

This panel has the following parts.

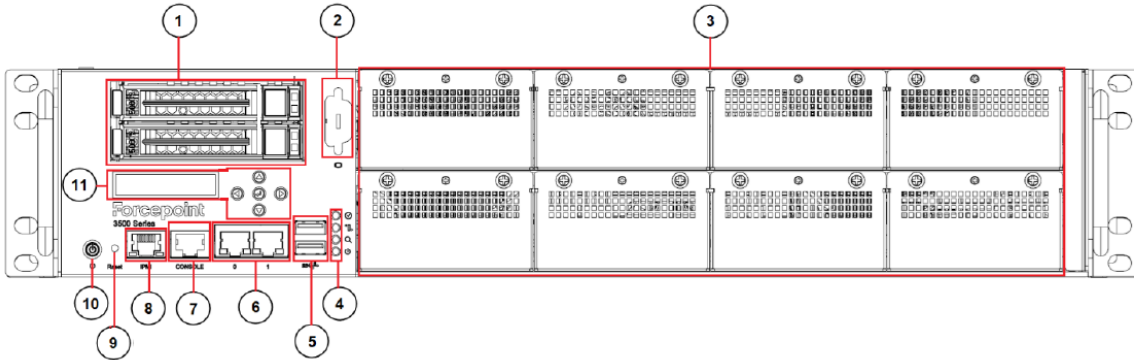

1 SSD slots 1–2.



Note

The appliance is shipped with two SSDs installed in mirroring (RAID 1) configuration. The upper is drive ID 1, and lower is drive ID 0 in monitoring and management tools.

2 VGA port.

3 Interface module slots

The upper slots are numbered 1–4 from left to right.

The lower slots are numbered 5–8 from left to right.

4 Indicator lights

5 USB ports 1–2 from top to bottom

6 Fixed Ethernet ports 0–1 from left to right.

The port names are eth0_0 and eth0_1.

7 Console port (speed 115,200 bps).

8 IPMI port (usage not recommended).

9 Reset button.

10 Power button.

11 LCD display and Display buttons. For more details on the LCD display, refer to the **LCD display** section.

Back panel

This panel has the following parts.

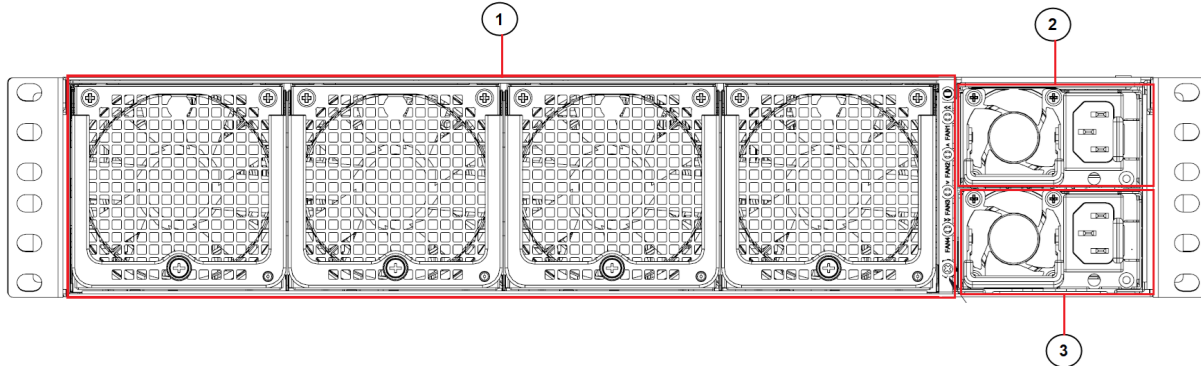

1 Fan bays 1–4

When the fan is on, the fan indicator light is green. The light flashes when the fan is starting up or if the appliance detects that the fan has failed. The airflow is from the front of the appliance to the back.

2 Power supply 1

When power is supplied to the appliance, the indicator light is green. The light is amber if a power cable is not connected. The light flashes to indicate a warning.

3 Power supply 2

When power is supplied to the appliance, the indicator light is green. The light is amber if a power cable is not connected. The light flashes to indicate a warning.

Indicator lights

Indicator lights show the status of the appliance and any fixed Ethernet ports.

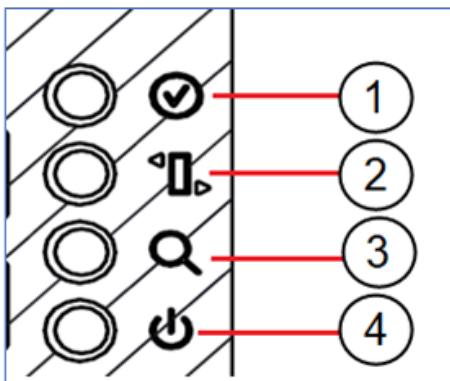

1 Status

2 Hardware status

3 UID

4 Power

Indicator	Color	Description
Status	Unlit	The initial configuration has not yet been generated.
	Green	<ul style="list-style-type: none"> Flashes when initial contact is established, but a policy has not been installed. Steady green when the Engine is online.
	Amber	<ul style="list-style-type: none"> Flashes while initial contact is being established. Steady amber when initial contact has been established, but the Engine is offline. Alternates with green when the Engine is in the standby state.
Hardware Status	Amber	The indicator turns on if the Power supply unit is not available or is not powered.
UID	Blue	<p>The UID LED can be lit for easy chassis identification from the web user interface accessible through the IPMI port.</p> <p>To light the UID LED, navigate to Remote Control > Front Panel and then select Chassis Identification / Identify.</p>
Power	Green	Power is supplied to the appliance.

Ethernet port indicators

Ethernet port indicators show the status and speed of the network ports.

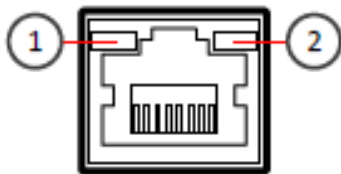

- 1 Link speed indicator
- 2 Activity/link indicator

Indicator	Color	Explanation
Activity/link indicator	Green	Link OK, flashes on activity.
Link speed indicator	Unlit	No link.
	Amber	100 Mbps link.
	Green	1 Gbps link.

SSD indicators

SSD indicators show the status of the SSDs.

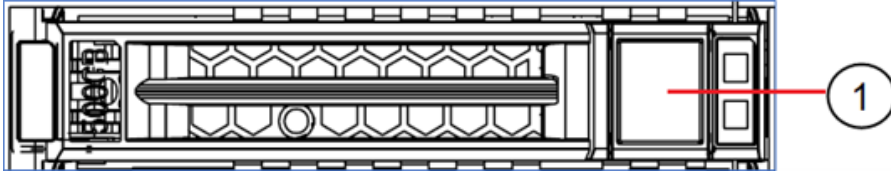

- 1 Disk indicator
Flashes blue when there is disk activity.
- 2 Power indicator
When lit green, an SSD is present in the drive bay.

Ethernet port names for appliances with interface modules

Ethernet port names are based on the slot and port numbers.

The first number in the name represents the slot on the appliance. The second number represents the port on the slot. For example, eth2_0 is located on port 0 of slot 2.

Component	Slot number	Port numbers
Fixed Ethernet ports	0	eth0_0, and eth0_1
Interface modules	1–8. The slot numbers for the interface modules start from 1 and increase from left to right starting from the top row.	The port numbers start from 0 and increase from left to right. For example, the port farthest to the left in slot 1 is eth1_0.

Supported interface modules

Forcepoint NGFW appliances support the following types of interface modules. For a list of all available interface modules and compatibility information, see Knowledge Base article [10245](#).



Note

Do not remove any stickers from modules — they contain important information.

Module	Identifier
8 port gigabit Ethernet RJ45	MODG8
8 port gigabit Ethernet RJ45 copper bypass module	MODG8B

Module	Identifier
4 port 10 gigabit Ethernet long reach bypass LC module	MOD10L4B
4 port 10 gigabit Ethernet short reach bypass LC module	MOD10S4B
2 port 40 gigabit Ethernet bypass MPO module	MOD40F2B

Module	Identifier
2 port 25 gigabit Ethernet SFP28	MOD25F2
2 port 40 gigabit Ethernet QSFP+	MOD40F2
1 port 100 gigabit Ethernet QSFP28	MOD100F1
4 port 10 gigabit Ethernet SFP+	MOD10F4
8 port gigabit Ethernet SFP	MODGF8
8 port 10 gigabit Ethernet SFP+	MOD10F8

The interface module slots are processed by different CPUs. For optimal performance, balance the modules between the two CPUs.

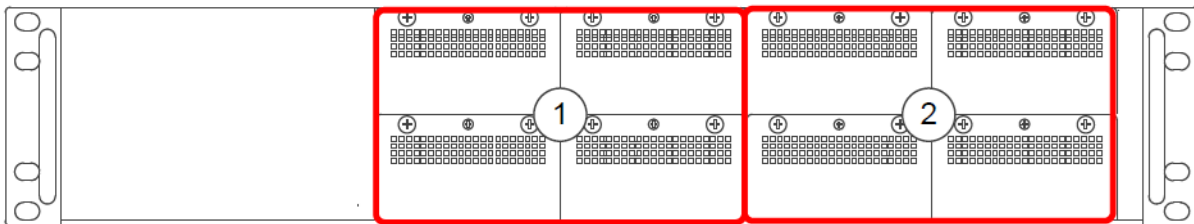

- 1 Interface module slots 1-2 and 5-6 are processed by CPU0.
- 2 Interface module slots 3-4 and 7-8 are processed by CPU1.

MODG8 module

The MODG8 module is an 8 port gigabit Ethernet RJ45 module.

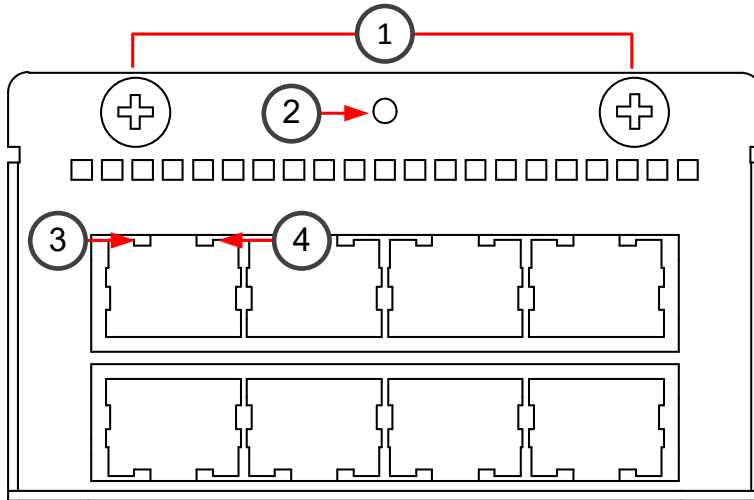

- 1 Thumbscrews**
You must unfasten the thumbscrews to replace or remove the module.
- 2 Fastening screw**
You must remove this screw to replace or remove the module.
- 3 Activity/link indicators**
When green, the link is OK. Flashes on activity.
- 4 Link speed indicators**
When green, the speed is 1 Gbps.
When amber, the speed is 100 Mbps.

MODG8B module

The MODG8B module is an 8 port gigabit Ethernet copper bypass module.

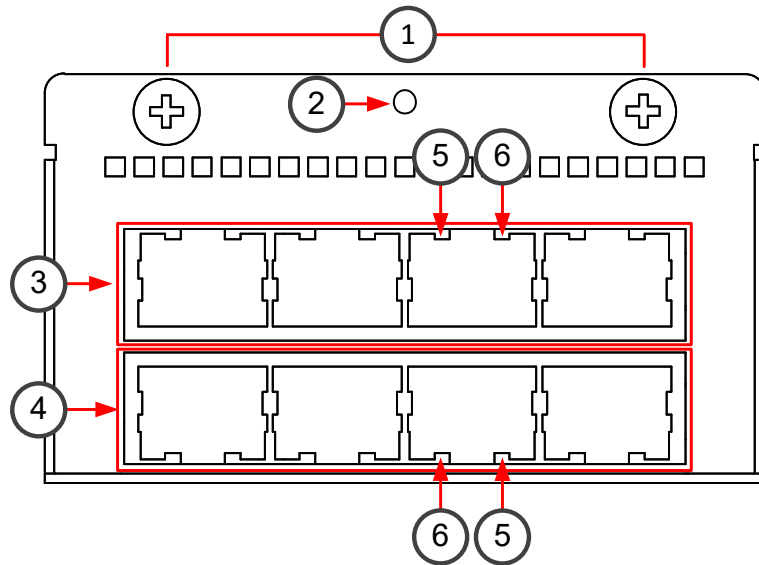

1 Thumbscrews

You must unfasten the thumbscrews to replace or remove the module.

2 Fastening screw

You must remove this screw to replace or remove the module.

3 Ethernet ports 4–7 from left to right

The Ethernet ports are used in the following even-odd pairs for bypass:

- 4–5
- 6–7

4 Ethernet ports 0–3 from left to right

The Ethernet ports are used in the following even-odd pairs for bypass:

- 0–1
- 2–3

5 Activity/link indicators

When green, the link is OK. Flashes on activity.

When amber, bypass mode is active.

6 Link speed indicators

When green, the speed is 1 Gbps.

When amber, the speed is 100 Mbps.

MOD10L4B module

The MOD10L4B module is a 4 port 10 gigabit Ethernet long reach bypass module with LC fiber connections.

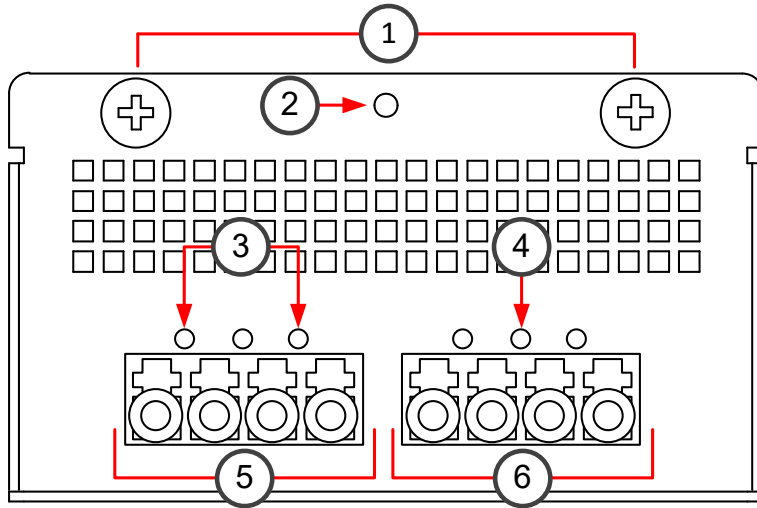

- 1** Thumbscrews
You must unfasten the thumbscrews to replace or remove the module.
- 2** Fastening screw
You must remove this screw to replace or remove the module.
- 3** Activity/link indicators
When green, the link is OK. Flashes on activity.
- 4** Bypass indicator
When amber, bypass mode is active.
- 5** Ethernet ports 0–1 from left to right
- 6** Ethernet ports 2–3 from left to right

The Ethernet ports are used in the following even-odd pairs for bypass:

- 0–1
- 2–3

MOD10S4B module

The MOD10L4B module is a 4 port 10 gigabit Ethernet short reach bypass module with LC fiber connections.

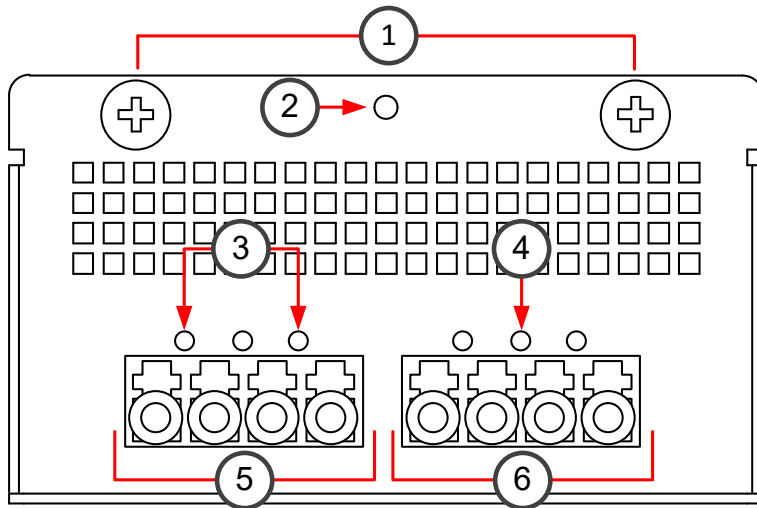

- 1** Thumbscrews
You must unfasten the thumbscrews to replace or remove the module.
- 2** Fastening screw
You must remove this screw to replace or remove the module.
- 3** Activity/link indicators
When green, the link is OK. Flashes on activity.
- 4** Bypass indicator
When amber, bypass mode is active.
- 5** Ethernet ports 0–1 from left to right
- 6** Ethernet ports 2–3 from left to right

The Ethernet ports are used in the following even-odd pairs for bypass:

- 0–1
- 2–3

MOD25F2 module

The MOD25F2 module is a 2 port 25 gigabit Ethernet SFP28 module.

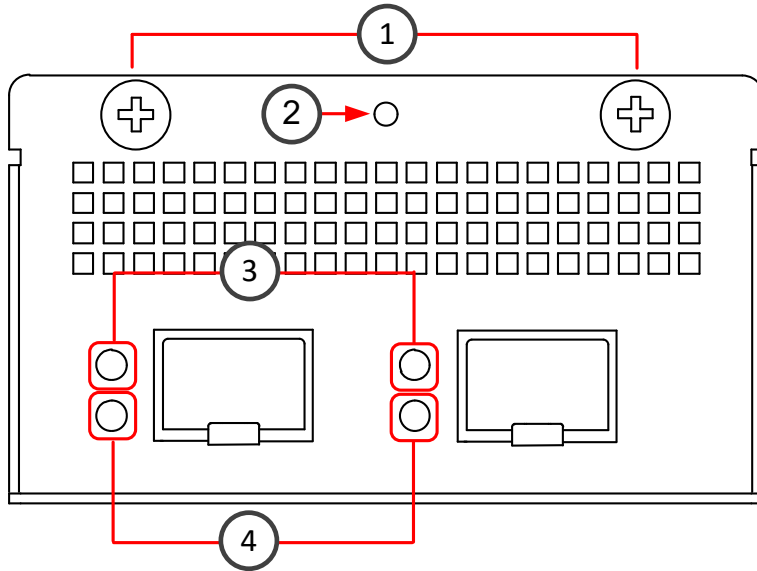

- 1 Thumbscrews**
You must unfasten the thumbscrews to replace or remove the module.
- 2 Fastening screw**
You must remove this screw to replace or remove the module.
- 3 Activity/link indicators**
The indicators are labeled with the port that is represented.
When green, the link is OK. Flashes on activity.
- 4 Link speed indicators**
When green, the speed is 25 Gbps.

MOD40F2 module

The MOD40F2 module is a 2 port 40 gigabit Ethernet QSFP+ module.

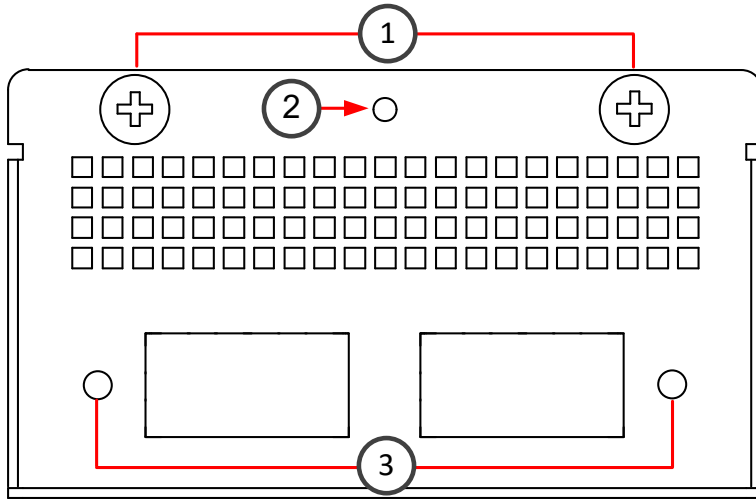

1 Thumbscrews

You must unfasten the thumbscrews to replace or remove the module.

2 Fastening screw

You must remove this screw to replace or remove the module.

3 Activity/link indicators

The indicators are labeled with the port that is represented.

When green, the link is OK. Flashes on activity.

MOD40F2B module

The MOD40F2B module is a 2 Port 40 gigabit Ethernet QSFP+ bypass module.

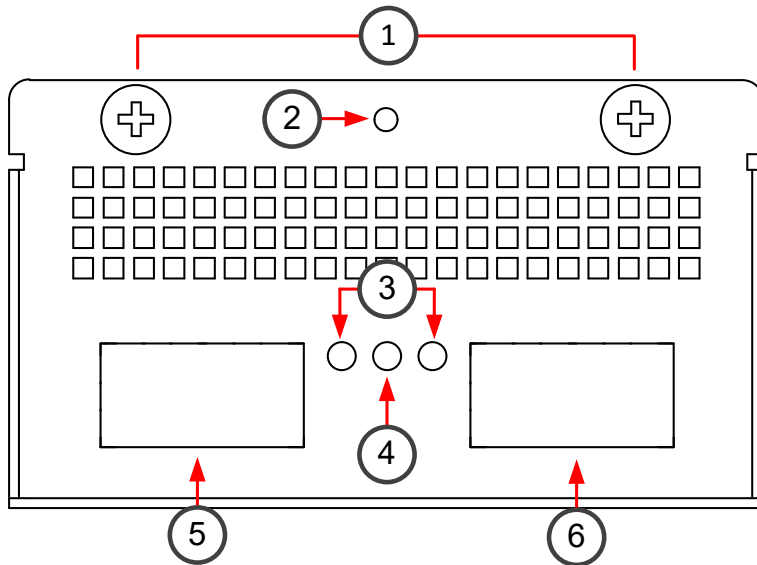

- 1** Thumbscrews
You must unfasten the thumbscrews to replace or remove the module.
- 2** Fastening screw
You must remove this screw to replace or remove the module.
- 3** Activity/link indicators
When green, the link is OK. Flashes on activity.
- 4** Bypass indicator
When amber, bypass mode is active.
- 5** Ethernet port 0
- 6** Ethernet port 1

The Ethernet ports are used in the following even-odd pair for bypass:

- 0-1

MOD10F4 module

The MOD10F4 module is a 4 port 10 gigabit Ethernet SFP+ module.

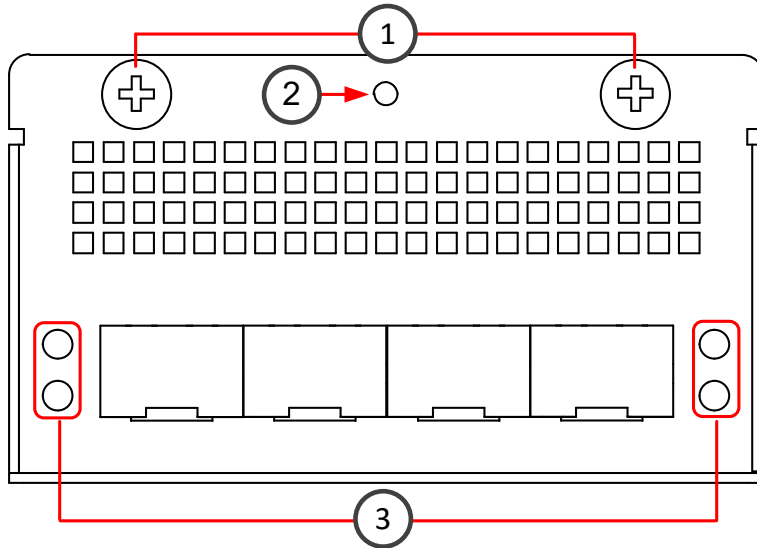

1 Thumbscrews

You must unfasten the thumbscrews to replace or remove the module.

2 Fastening screw

You must remove this screw to replace or remove the module.

3 Activity/link indicators

The indicators are labeled with the port that is represented.

When green, the link is OK. Flashes on activity.

MODGF8 module

The MODGF8 module is an 8 port gigabit Ethernet SFP module.

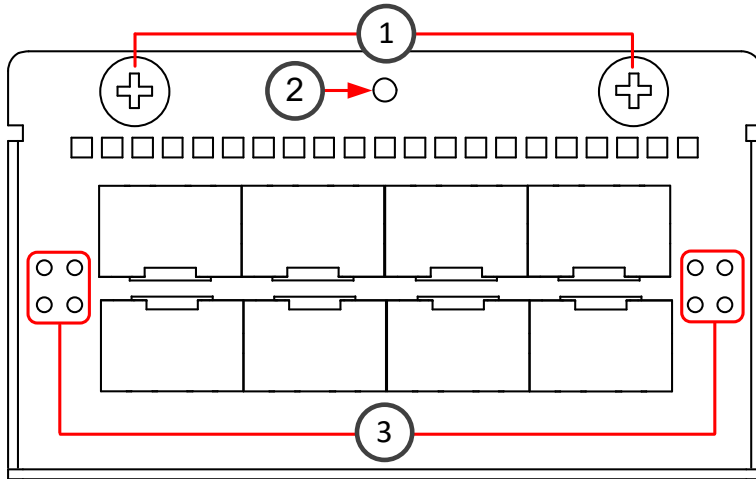

1 Thumbscrews

You must unfasten the thumbscrews to replace or remove the module.

2 Fastening screw

You must remove this screw to replace or remove the module.

3 Activity/link indicators

The indicators are labeled with the port that is represented.

When green, the link is OK. Flashes on activity.

MOD10F8 module

The MOD10F8 module is an 8 port 10 gigabit Ethernet SFP+ module.

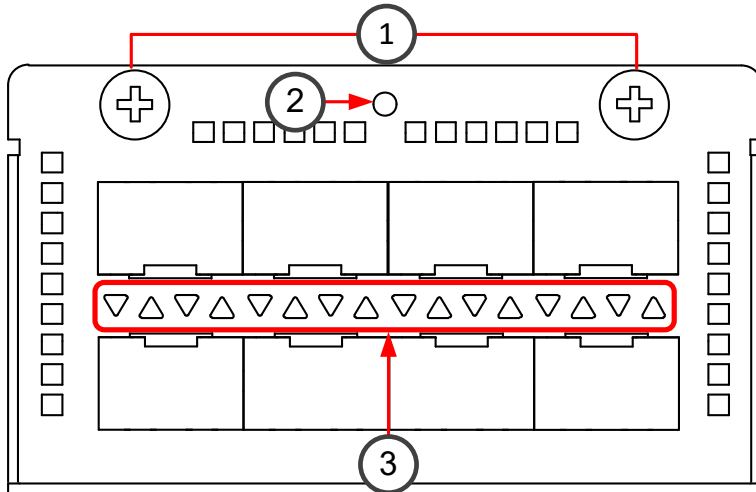

1 Thumbscrews

You must unfasten the thumbscrews to replace or remove the module.

2 Fastening screw

You must remove this screw to replace or remove the module.

3 Link status and speed indicators

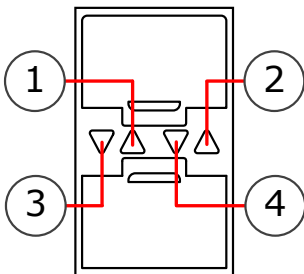

- 1** Link speed indicator for the upper port
When green, the link speed is 10 Gbps.
- 2** Link status indicator for the upper port
When blue, the link is OK.
- 3** Link speed indicator for the lower port
When green, the link speed is 10 Gbps.
- 4** Link status indicator for the lower port
When blue, the link is OK.

MOD100F1 module

The MOD100F1 module is a 1 port 100 gigabit Ethernet QSFP28 module.

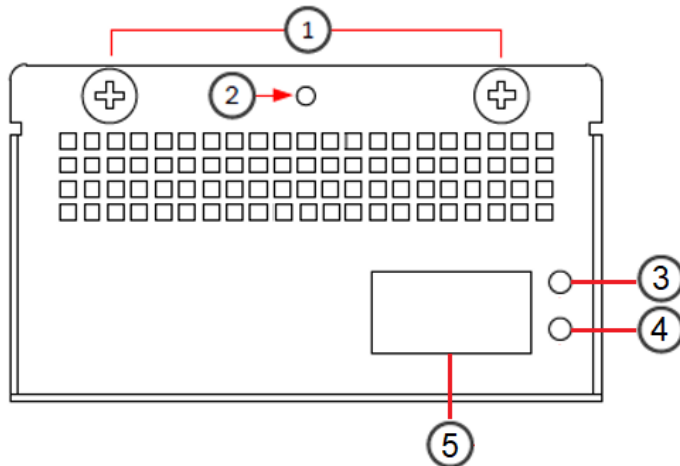

1 Thumbscrews

You must unfasten the thumbscrews to replace or remove the module.

2 Fastening screw

You must remove this screw to replace or remove the module.

3 Activity/link indicators

The indicators are labeled with the port that is represented.
When green, the link is OK. Flashes on activity.

4 Link speed indicator

When green, the link speed is 100 Gbps.

5 Ethernet port 0

LCD display

The LCD display shows **Forcepoint** logo when it is idle. You can access status information by pressing any of the display buttons to the right side of the display.

```

NODE>s - 51 - 181
VER. 6.10.14
POL. Allow-all-no-log
STAT + 12% D0:- D1:-
  
```

The data is displayed by line:

- 1) **NODE:** The node name (hostname).
- 2) **VER.:** The engine version (three levels).
- 3) **POL.:** Name of the policy that is running on the engine (can be null policy).
- 4) **STAT:**
 - Statuses for engine:
 - + for online.
 - - for offline.
 - Load percentage. For example, 12%.
 - Statuses for RAID 1 array disks:
 - + for online.
 - / for rebuilding.
 - - for missing or degraded.



Note

- The displayed information is refreshed at intervals of 6 seconds.
- The **Caret (>)** symbol in a line denotes the active line and actions can be performed on that line. Press the **Up** (⬆) or **Down** (⬇) key to move the **Caret** symbol to another line.
- If the value at the active line is not completely visible, the **Left** (⬅) or **Right** (➡) key can be used to scroll the value to view the complete information.
- Press the **Enter** (↵) key to display the beginning of the value in a line.
- A scrolled value is displayed with ... in the beginning of the value.

Precautions

The precautions provide safety guidance when working with Forcepoint appliances and electrical equipment.



CAUTION

Forcepoint appliances cannot be serviced by end users. Never open the appliance covers for any reason. Doing so can lead to serious injury and void the hardware warranty.

For additional safety information, see the *Forcepoint Product Safety and Regulatory Compliance Guide*.

General safety precautions

Read the safety information and follow these rules to ensure general safety whenever you are working with electronic equipment.

- Keep the area around the appliance clean and free of clutter.

- When lifting the appliance, two people at each end should lift slowly with their feet spread out to distribute the weight. Always keep your back straight and lift with your legs.
- Use a regulating uninterruptible power supply (UPS) to keep your system operating during power failures and to protect the appliance from power surges and voltage spikes.
- If you need to turn off or unplug the appliance, always wait at least five seconds before turning on or plugging in the appliance again.

Operating precautions

Follow these precautions when operating the appliance.

- Do not open the power supply casing. Only the manufacturer's qualified technician is allowed to service power supplies.

Electrical safety precautions

Follow basic electrical safety precautions to protect yourself from harm and the appliance from damage.

- Know the locations of the power on/off button and the emergency turn-off switch, disconnection switch, or electrical outlet for the room. If an electrical accident occurs, you can quickly turn off power to the system.
- When working with high-voltage components, do not work alone.
- Turn off the system and disconnect the power before removing or installing system components that are not hot-swappable.
- When working with electrical equipment that is turned on, use only one hand. This is to avoid making a complete circuit, which causes an electric shock. Use extreme caution when using metal tools, which can easily damage any electrical components or circuit boards the tools come into contact with.
- Do not use mats designed to decrease electrostatic discharge as protection from electric shock. Instead, use rubber mats that have been designed as electrical insulators.
- If the power supply cable includes a grounding plug, the plug must be plugged into a grounded electrical outlet.
- Use only the power cable or cables supplied with the appliance.
- To avoid injury, do not open the enclosures of power supplies or solid-state drives (SSDs).



Note

On appliances that have two power supplies, we recommend that you use both power supplies for redundancy.

AC power supply safety precautions

The appliance power inlet is the disconnect device on the appliance.

Install the appliance

There are several tasks that must be completed before the appliance is installed.

These tasks and the installation of the appliance might be done by the same person or by different persons:

- The Security Management Center (SMC) administrator is responsible for the tasks that are needed before the appliance is installed.
- The on-site installer is responsible for installing the appliance.

For more information, see the *Forcepoint Next Generation Firewall Installation Guide*.

To prepare for the appliance installation, the SMC administrator must do the following:

- 1) If the SMC has not yet been installed, install the SMC.



Important

Do not install the SMC on the NGFW appliance. The SMC can manage many NGFW appliances.

- 2) In the Management Client component of the SMC, create and configure the NGFW Engine element that represents the appliance.
- 3) In the Management Client component of the SMC, save the initial configuration. The SMC administrator must either:
 - Upload the initial configuration to the Installation Server for plug-and-play configuration of the appliance.



Note

There are additional requirements for plug-and play configuration. See Knowledge Base article [9662](#).

- Give the on-site installer a USB drive that contains an initial configuration file for each appliance.

The on-site installer must do the following:

- 1) Inspect the appliance, delivery box, and all components included in the shipment.



Important

Do not use damaged appliances or components.

- 2) Connect all necessary power, network cables and other components, and then press the power button to turn on the appliance. If the plug-and-play configuration method is not used, the on-site installer must use the USB drive that contains the initial configuration files to configure the NGFW Engine software.
- 3) When you have finished installing the appliance, inform the SMC administrator so that the administrator can check the status of the appliance in the Management Client.

Rack-mount the appliance

The rack-mounting procedure varies depending on the type of rack unit. If needed, see the documentation for your rack unit.



Important

Read the safety precautions before you rack-mount the appliance. Do not install the appliance upside down.

Determine the placement of each component in the rack.

- Install the heaviest components on the bottom of the rack first. Install components from the bottom to the top.
- The appliance must be connected to a grounded power outlet.
- Use a UPS to protect the appliance from power surges and voltage spikes, and to keep your system operating if there is a power failure.
- To maintain proper cooling, always keep the front door of the rack and all panels and components on the appliances closed when not servicing.

Install the appliance in a four-post rack using fixed brackets

Use the supplied long fixed brackets to install the appliance in a four-post rack.

Steps

- 1) Attach a long bracket to each of the back posts of the rack.
- 2) Attach three screws to each side of the appliance.
- 3) Lift the appliance into the rack, and guide the screws in the side of the appliance into the groove of the bracket.
The bracket is used to support the appliance when setting the depth of the appliance in the rack.
- 4) Attach the front panel to the front posts of the rack with four screws in each post.

Result

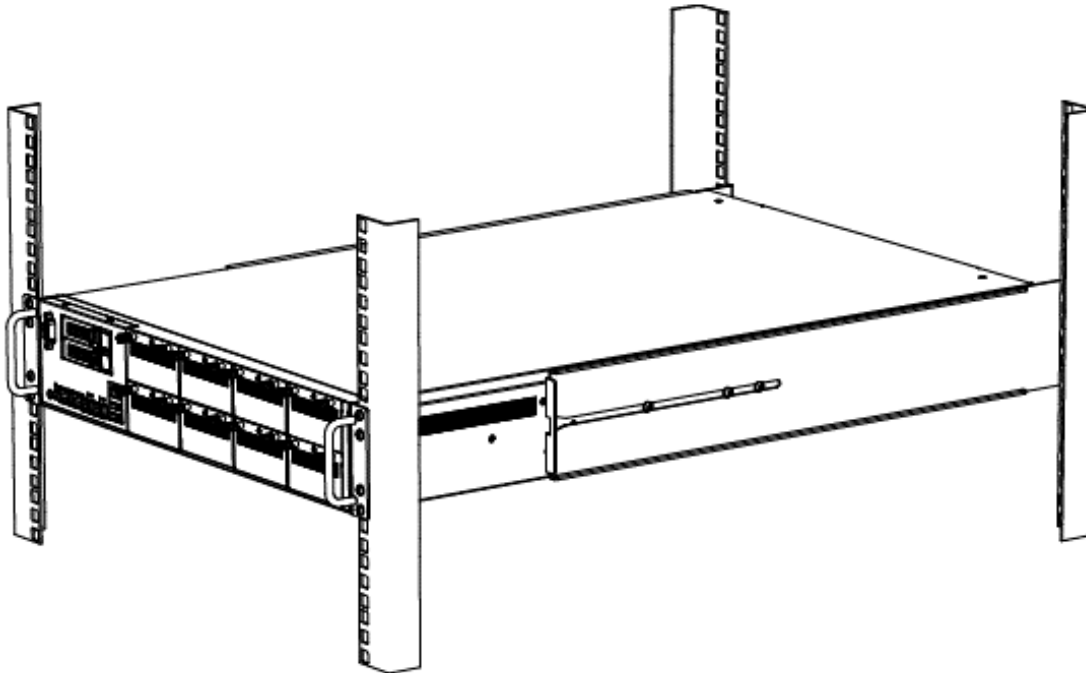

Install the appliance in a four-post rack using sliding brackets

Use the supplied sliding brackets to install the appliance in a four-post rack.

Steps

- 1) Locate the brackets for the rack installation.

- 2) Detach the inner rails from the outer rails. Press down the locking tab to pull out the inner rail.

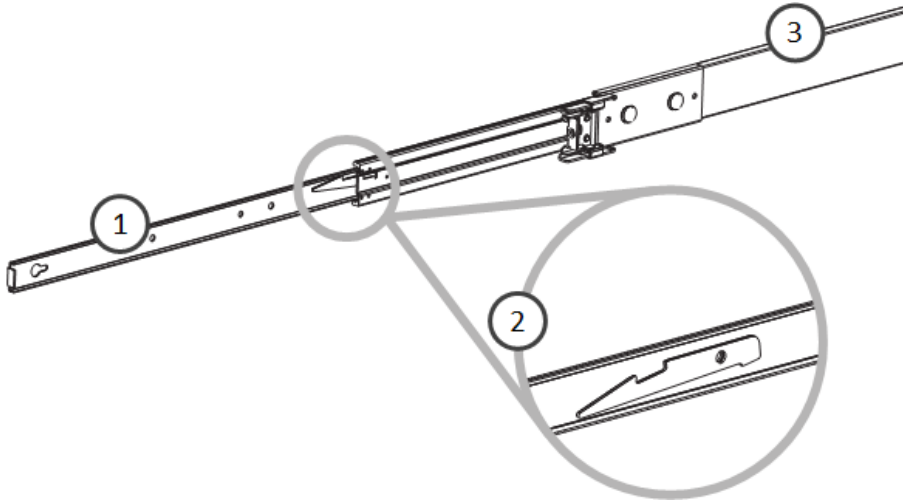

- 1 Inner rail
- 2 Locking tab
- 3 Outer rail

- 3) Attach an inner rail to each side of the appliance:
 - a) Tighten the five screws to the five holes on the side of the appliance.



Note

Do not attach the inner rail to the appliance now.

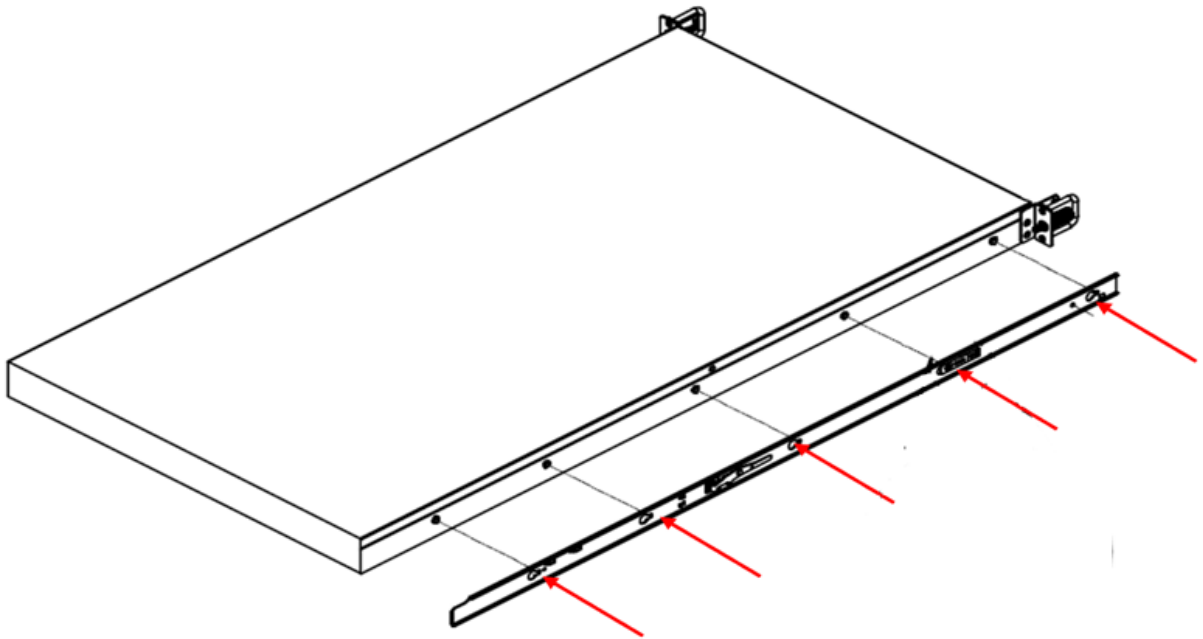

- b) Align the 5 holes on the inner rail with the screws on the side of the appliance.
 - c) Press the inner rail against the side of the appliance, and then slide the rail towards the rear of the appliance to lock it.

4) Attach the outer rail to the rack:

- **For front rack post:** Lift the lever, and then aim the rack mount pin to the rack post and push forward.
- **For back rack post:** Lift the lever, and then aim the rack mount pin to the rack post and pull back.

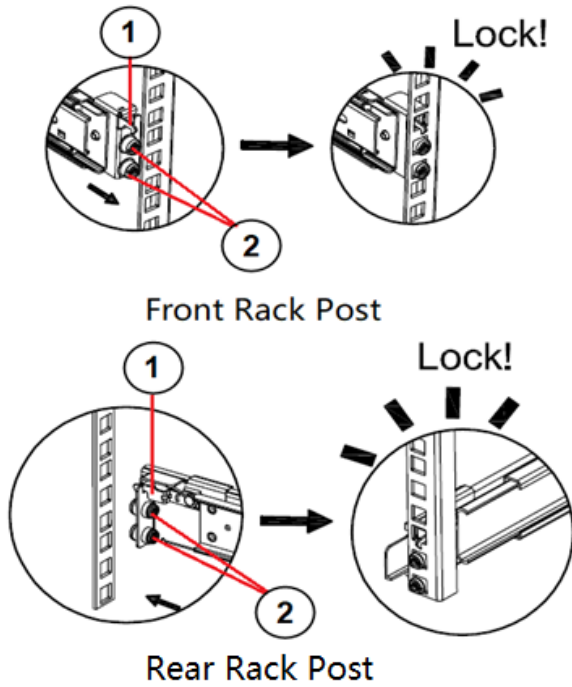

- 1 Lever
- 2 Mount pin

- 5) Mount the appliance in the rack:
 - a) Make sure the ball bearing retainer is locked forward.
 - b) Pull the middle rail out of the outer rail until locked.
 - c) Align the rear of the inner rails with the front of the outer rails.
 - d) Push the appliance into the rack.

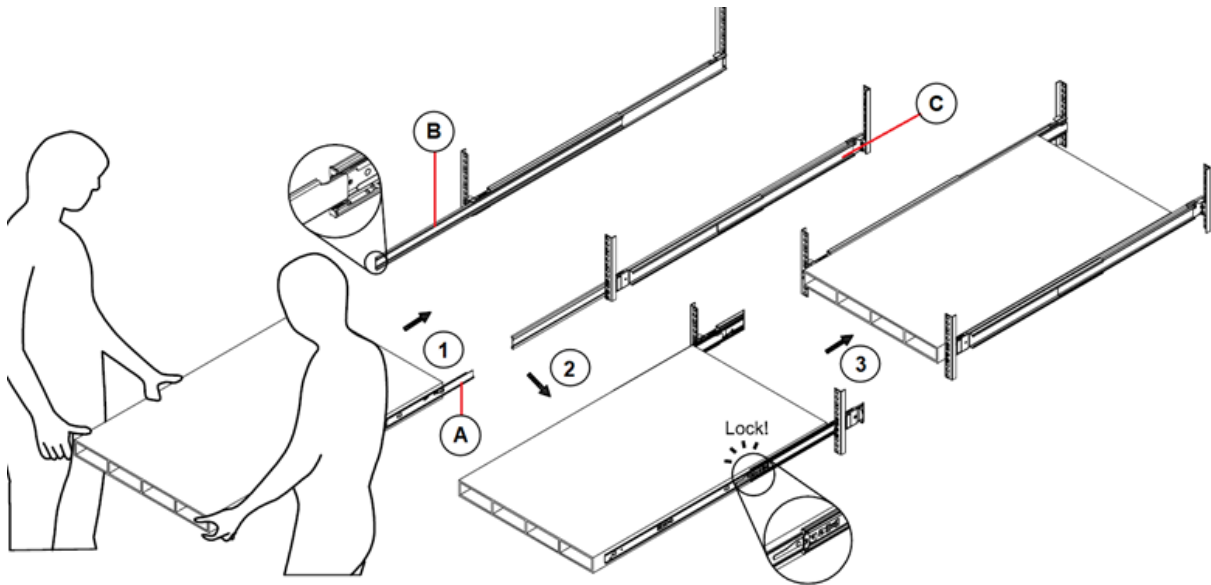

- A Inner rail
- B Middle rail
- C Outer rail

Install an interface module

If you have interface modules, install them in the appliance.

Before you begin

Read the safety precautions and make sure any interface modules you install are the correct type for your appliance.



CAUTION

To avoid damaging the modules or the appliance, do not install or remove any interface modules if the appliance is turned on.

**Important**

You must install an interface module or a placeholder module in each slot before making the appliance operational.

**Note**

We recommend fastening a grounding strap to your wrist so that it contacts your bare skin and attaching the other end of the strap to the appliance.

Steps

- 1) Locate the slot to install the module in.
- 2) If the interface slot is covered with a plate, unfasten the thumbscrews that attach the plate to the interface module slot.

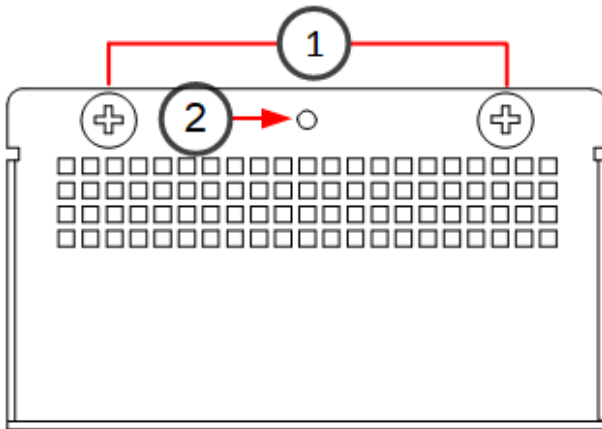

- 1 Thumbscrews
- 2 Fastening screw

- 3) Use a screwdriver to remove the fastening screw.
- 4) Remove the plate.
Store the plate for later use in case you want to use the appliance without an interface module.
- 5) Push the module into the slot.
The module is seated correctly when the front panel of the module is even with the front panel of the appliance.

**Important**

Do not insert the module in the wrong orientation. Inserting the modules incorrectly might damage the appliance and the modules and voids the warranty.

- 6) Push the thumbscrews on the module in, then tighten them to secure the module in place.
- 7) Use a screwdriver to reattach the fastening screw.

Connect the cables

Connect the network and power cables.



CAUTION

On appliances that have an Intelligent Platform Management Interface (IPMI) port, the IPMI port is disabled by default. We recommend leaving the IPMI port disabled with no cable attached due to the risk of unauthorized access. Ensure best practices are followed if you decide to enable it. For more information, see the [Configuring accesses via IPMI interface in 3500 Series appliances](#) KBA.

Use at least CAT5e-rated cables for gigabit networks. Always use standard cabling methods. Use crossover cables to connect the appliance to hosts and straight cables to connect the appliance to switches or hubs. For more information, see the *Forcepoint Next Generation Firewall Installation Guide*.

Network interfaces at both ends of each cable must have identical speed and duplex settings. These settings include the automatic negotiation setting. If one end of the cable uses autonegotiation, the other end must also use autonegotiation. Gigabit standards require interfaces to use autonegotiation. Fixed settings are not allowed at gigabit speeds.

The settings for inline interfaces must be identical for all four interfaces. The pair on the appliance and the interfaces on the two devices connecting to the appliance must have the same speed and duplex settings configured.

Ethernet port mapping

For appliances that have removable interface modules, Ethernet port names are based on the slot and port numbers.

The first number in the name represents the slot on the appliance, and the second number represents the port on the slot. For example, eth2_0 is located on port 0 of slot 2.

- Slot 0 is used for the fixed Ethernet ports.
- Slots 1 and higher are used for the ports on the interface modules.
The port numbers start at 0 and increase from left to right.

During the initial configuration of the appliance, you map the Ethernet ports to the interface IDs that you defined in the Management Client.

The NGFW Configuration Wizard shows the mapping between the interface IDs and port names. In the command line version of the NGFW Configuration Wizard, interface IDs appear in the **ID** column and port names appear in the **Name** column.

This mapping can change if you replace an interface module. If the new module has more Ethernet ports, the interface IDs for the new ports start from the next free interface ID number.

Example: You have thirteen interfaces numbered 0–12, which includes a four-port module installed in slot 1. If you replace the four-port module installed in slot 1 with a two-port module, eth1_2 with ID 10 and eth1_3 with ID 11 are removed.

Example before and after ID mapping

ID	Name	Driver
	modem0	
0	eth0_0	igb
1	eth0_1	igb
2	eth0_2	igb
3	eth0_3	igb
4	eth0_4	ixgbe
5	eth0_5	ixgbe
6	eth0_6	ixgbe
7	eth0_7	ixgbe
8	eth1_0	igb
9	eth1_1	igb
10	eth1_2	igb
11	eth1_3	igb
12	wlan0	ath10k_pci
	<Add..>	<Autod



ID	Name	Driver
	modem0	
0	eth0_0	igb
1	eth0_1	igb
2	eth0_2	igb
3	eth0_3	igb
4	eth0_4	ixgbe
5	eth0_5	ixgbe
6	eth0_6	ixgbe
7	eth0_7	ixgbe
8	eth1_0	igb
9	eth1_1	igb
12	wlan0	ath10k_pci
	<Add..>	<Add..>

Connect network and management cables

Connect the appliance to your networks. The management connection allows you to view the system console.

**Note**

Ethernet ports are mapped to interface IDs during the initial configuration. The ports and port numbers of the physical appliance must match the interface definitions and interface IDs configured for the engine in the Management Client.

Steps

- 1) Determine which Ethernet ports to use and connect the ports to your networks.
- 2) Select one of these options for the management connection depending on the appliance model and features:
 - Connect a null-modem cable to the console port of the appliance and to another computer for a terminal connection.
 - Connect a monitor to the VGA port and a keyboard to a USB port.

Connect network cables to SFP ports

If you installed an SFP interface module on the appliance or the appliance has an integrated SFP port, insert the copper or fiber-optic SFP transceiver into the port, then connect the cables.

Steps

- 1) Insert the SFP transceiver in the port slot until you feel the connector on the transceiver snap into place.



Note

Make sure that the latch on the SFP transceiver is up when you insert the SFP transceiver in the port slot.

- 2) If the SFP transceiver has a rubber plug, remove the plug.
- 3) Connect the copper or fiber-optic cable to the SFP transceiver.



Note

Each SFP port must match the wavelength specifications at the other end of the cable. The cable must not exceed the stipulated cable length for reliable communications.

Connect the power supplies

Connect power cables to the power supplies on the back of the appliance.

Before you begin

See the safety precautions topic for information about power supplies.

We highly recommend the following configurations.

- On appliances that have two power supply modules for redundant power sources, connect both power supplies to a power source. Connecting both power supplies ensures that the appliance can function if one of the power supplies fails.
- Use a UPS to ensure continuous operation and minimize the risk of damage to the appliance in case of sudden loss of power. For a truly redundant power supply, connect each power connector on the appliance to a different UPS, so that the failure of one UPS does not cut power to both power supplies.



Note

After connecting the power cables, the power button on the appliance is operational after about 30 seconds.



Note

Standby power is supplied to the system even when the appliance is turned off.

Steps

- 1) Connect the power cables to the power connectors on the back of the appliance.
- 2) Plug the power cable into a grounded, high-quality power strip that offers protection from electrical noise and power surges.

Port settings for plug-and-play configuration method

If you use the plug-and-play configuration method for a single NGFW appliance, the appliance uses Ethernet port 0 to contact the Installation Server.

To use the plug-and-play configuration method, the interface that corresponds to Ethernet port 0 in the initial configuration must have a dynamic IPv4 address.

Maintenance

Forcepoint NGFW appliances ship with replaceable components.

Turn off the appliance

Most Forcepoint NGFW appliance hardware components are not hot-swappable.

You can turn off the appliance by using one of the following ways:

- Short press of the Power button
- Using the Management Client
- From the Engine command line

Turn off the appliance using the power button

Power button includes the functions:

- Short press of the power button initiates software interfaces driven graceful power off. This is the recommended way to turn the power off using power button.
- Long press of the power button (over 2 seconds) initiates forceful power off. This option is used only if the appliance does not respond to graceful power off in 30 seconds.

Turn off the appliance using the Management Client

The SMC administrator can also turn off the appliance remotely using the Management Client. For more information, see the *Forcepoint Next Generation Firewall Product Guide*.

Turn off the appliance from the Engine command line

Steps

- 1) Connect to the Engine command line.

Depending on the appliance type, use one of the following options:

- Connect a computer running a terminal emulator program to the appliance console port, then press **Enter**.
- Connect using SSH.



Note

SSH access is not enabled by default.

- 2) Enter the logon credentials.

The user name is `root` and the password is the one you set for the appliance.

- 3) Enter the following command:

```
halt
```

- 4) Wait until the power indicator light turns red or is unlit, then unplug all power cables from the appliance.

Replace the power supply

The power supplies are replaceable on most Forcepoint NGFW appliances. If both power supplies are connected to a power source, the power supplies are hot-swappable.



CAUTION

Do not open the casing of a power supply module. Power supply modules can only be repaired by a qualified technician from the manufacturer.



Note

We recommend fastening a grounding strap to your wrist so that it contacts your bare skin and attaching the other end of the strap to the appliance.

Steps

- 1) Disconnect the power cable from the power supply module.
- 2) Locate the release tab for the power supply module.
- 3) Push the release tab to release the power supply module from its locking position.
- 4) Pull out the power supply module using the handle provided.
- 5) Push the replacement power supply module into the power slot until it clicks in place.

Replace the appliance fans

Replace failed fans to ensure proper cooling of the appliance.

We recommend that you replace all appliance fans if one of the fans fails.

The fans are hot-swappable.



CAUTION

Do not remove all fans at the same time if the appliance is running.

**Note**

We recommend fastening a grounding strap to your wrist so that it contacts your bare skin and attaching the other end of the strap to the appliance.

Steps

- 1) Loosen the thumbscrews that hold the fan in place to release the fan from its locking position.
- 2) Remove the fan from the appliance, then slide the new fan into the fan housing.
- 3) Tighten the thumbscrews that hold the fan in place.

Replace the SSD

Replace an SSD with another of the same model.

There are two SSD slots on the front panel of the appliances. The appliance model 3510 uses mirror (RAID 1) configuration with two SSD disks. For managing the mirror configuration if the mirror status gets degraded, refer to the *RAID array disc operations* Knowledge Base Article (KBA).

**Important**

- If both SSDs are present and RAID 1 is enabled, the appliance supports hot swapping so that a degraded SSD may be replaced while the appliance is turned on and the engine is running. For more details on how to hot swap an SSD, refer to the **Hot swapping an SSD** section.
- If only one SSD is present or RAID 1 is not enabled, follow the steps below to replace the SSD.

**Note**

We recommend fastening a grounding strap to your wrist so that it contacts your bare skin and attaching the other end of the strap to the appliance.

**CAUTION**

Uninstalled SSDs are sensitive to damage from electrostatic discharge.

Steps

- 1) Turn off the appliance and disconnect any power cables.
- 2) Press the Release button to open the SSD bay cover.

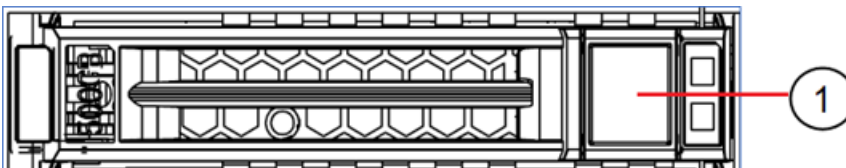

1 Release button

- 3) Pull the SSD tray out of the SSD bay.
- 4) Remove the SSD from the tray, then insert the new SSD into the tray.
- 5) Insert the SSD tray into the same SSD bay.
- 6) Close the cover of the SSD bay.
- 7) Rebuild the RAID array. For more information, refer to *RAID array disc operations* KBA.

Hot Swapping an SSD

Hot swapping of a degraded SSD is only supported if both SSDs are present and RAID 1 is enabled for the appliance.

For details on how to identify the degraded SSD, refer to the **LCD Display** section for status indications and the **Front panel** section for disk locations. Ensure that only the degraded SSD is replaced and that the rebuild is completed. Failure to do so may result in disk corruption.

Steps

- 1) Press the Release button to open the SSD bay cover of the degraded SSD.

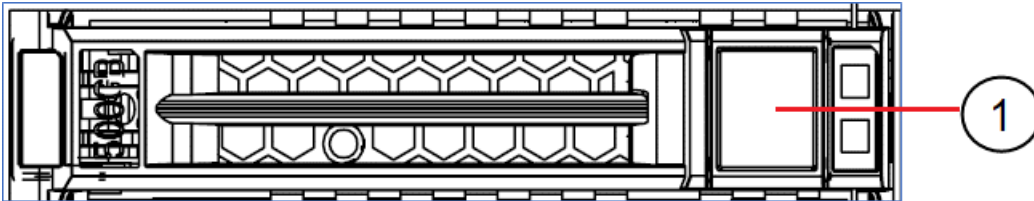

1 Release button

- 2) Pull the SSD tray out of the SSD bay.
- 3) Remove the SSD from the tray, then insert the new SSD into the tray.
- 4) Insert the SSD tray into the same SSD bay.
- 5) Close the cover of the SSD bay.
- 6) Wait for the rebuild of SSD RAID array to complete.



Note

After the SSD hot swapping is done the SSD RAID rebuild starts automatically.

Replace an interface module

Replace an interface module with the same type or a different type of module.

If the appliance was delivered with a plate that covered the interface slot, you can alternatively cover the interface slot with the plate instead of replacing the interface module with another module.



Note

We recommend fastening a grounding strap to your wrist so that it contacts your bare skin and attaching the other end of the strap to the appliance.

Steps

- 1) Turn off the appliance and disconnect any power cables.
- 2) To release the module, unscrew the thumbscrews.

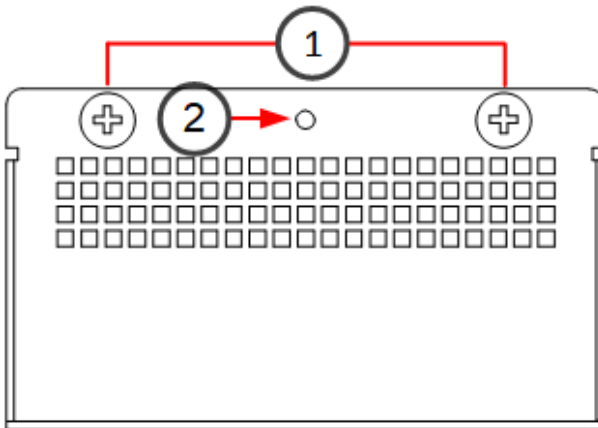

- 1 Thumbscrews
- 2 Fastening screw

- 3) Use a screwdriver to remove the fastening screw.
- 4) Carefully pull the module out of the slot.
- 5) Insert the new module.
- 6) Push and hold the thumbscrews on the module, then tighten them to secure the module in place.
- 7) Use a screwdriver to reattach the screw that secures the module.
- 8) Connect the cables and plug the power cables to the system and to the wall outlets.

- 9) Turn on the appliance.

**CAUTION**

To ensure proper cooling, do not turn on the appliance if you have not installed an interface module or a placeholder module in each slot. For some appliances, you can install the cover plate over the slot instead.

- 10) Update the interface configuration.

- a) On the command line of the NGFW Engine, enter the following command to start the NGFW Configuration Wizard:

```
sg-reconfigure
```

- b) In the network interface configuration options, make sure that the autodetected information is correct and that all interfaces have been detected.
If autodetection fails, add network drivers manually. For detailed instructions, see the *Forcepoint Next Generation Firewall Installation Guide*.
- c) If the number of ports in the new module differs from the old module, adjust the mapping of interfaces to interface IDs.

**CAUTION**

Do not select the **Clear** action when modifying interface IDs in the NGFW Configuration Wizard on the command line. Selecting **Clear** removes all mapping information between interface IDs and Ethernet ports, and restores the default values.

- d) On the **Prepare for Management Contact** page, highlight **Finish**, then press **Enter**.
- e) If the number of ports in the new module differs from the old module, modify the interface definitions in the Management Client, then refresh the policy to transfer the interface changes to the engine.
Make sure to use the same interface IDs that you mapped to the interfaces in the NGFW Configuration Wizard for the interface definitions in the Management Client.

Reattach the cover plate to the interface module slot

Reattach the module cover plate if there is no module in the slot.

**CAUTION**

Do not turn on the appliance if a slot is empty or uncovered. Using the appliance without an interface module or the cover plate can damage the appliance and voids the warranty.

**Note**

We recommend using a grounding strap to avoid electrostatic discharge. Make sure the strap touches your bare wrist and connect the other end to an unpainted part of the appliance or grounding screw.

Steps

- 1) Turn off the appliance.
- 2) Remove the interface module from the interface module slot.
- 3) Locate the tab at the lower left corner of the plate.
- 4) Insert the tab into the hole in the lower left corner of the slot casing.
- 5) Slide the plate inward until it covers the slot and the thumbscrew in the plate aligns with the screw hole to the right of the slot.
- 6) Push and hold the thumbscrews on the plate, then tighten them to secure the plate in place.

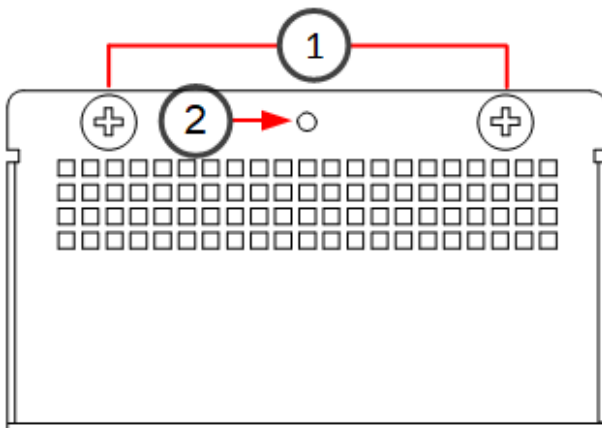

- 1 Thumbscrews
- 2 Fastening screw

- 7) Use a screwdriver to reattach the fastening screw.

Remove SFP transceivers

You can remove or replace SFP transceivers.

**CAUTION**

Invisible laser radiation is emitted from the end of a fiber-optic cable and from the fiber port. Do not stare into the beam and avoid direct exposure to the beam.



Note

We recommend fastening a grounding strap to your wrist so that it contacts your bare skin and attaching the other end of the strap to the appliance.

Steps

- 1) Disconnect the cable from the SFP transceiver.
- 2) Pull down the latch on the transceiver, then carefully pull the SFP transceiver out of the port slot.
- 3) If needed, insert a replacement SFP transceiver in the slot.

