



Next Generation Firewall

120 Series (Rev: 1)

Models N120W (APP-120C1),
N120WL (APP-120C2), N120
(APP-120C3), N120L (APP-120C4),
and N125L (APP-120C5)
Internet Security Device

Hardware Guide

Contents

- Introduction on page 2
- Find product documentation on page 2
- Model N120 features on page 3
- Model N120W features on page 5
- Model N120WL features on page 7
- Model N120L and N125L features on page 10
- Indicator lights on page 12
- Ethernet port indicators on page 14
- Precautions on page 14
- Install the appliance on page 16
- Maintenance on page 23
- Compliance information on page 26

Introduction

Thank you for choosing a Forcepoint appliance.

Familiarize yourself with the appliance ports and indicators and learn how to install the appliance safely.

Find product documentation

In the Forcepoint Customer Hub, you can find information about a released product, including product documentation, technical articles, and more.

You can get additional information and support for your product in the Forcepoint Customer Hub at <https://support.forcepoint.com>. There, you can access product documentation, release notes, Knowledge Base articles, downloads, cases, and contact information.

You might need to log on to access the Forcepoint Customer Hub. If you do not yet have credentials, create a customer account. See To create a customer account, navigate to the Customer Hub Home page, and then click the **Create Account** link..

Model N120 features

The figures and tables show the appliance components and features.

Front panel

This panel has the following parts.

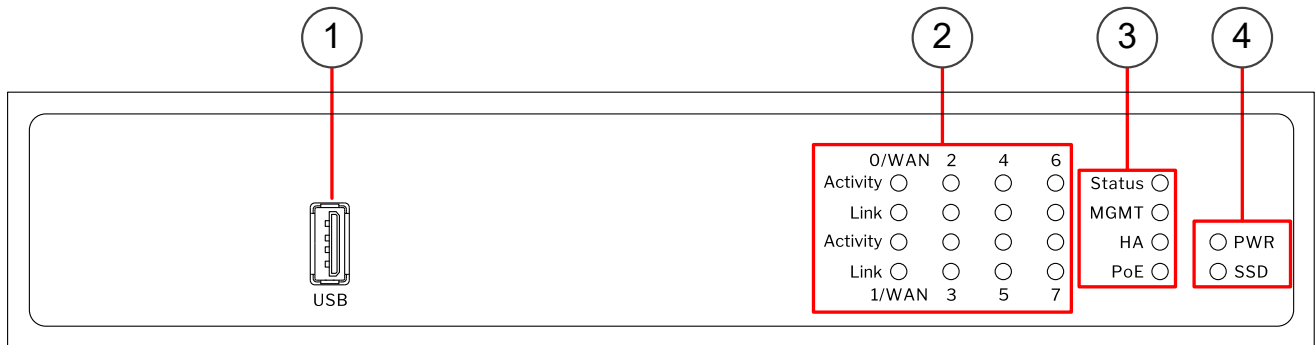

- 1 USB port
- 2 Indicators for Ethernet interface port activity and link status
- 3 Indicators for status, management (MGMT), high availability (HA), and power over Ethernet (PoE)
- 4 Indicators for power (PWR) and disk activity (SSD)

Back panel

This panel has the following parts.

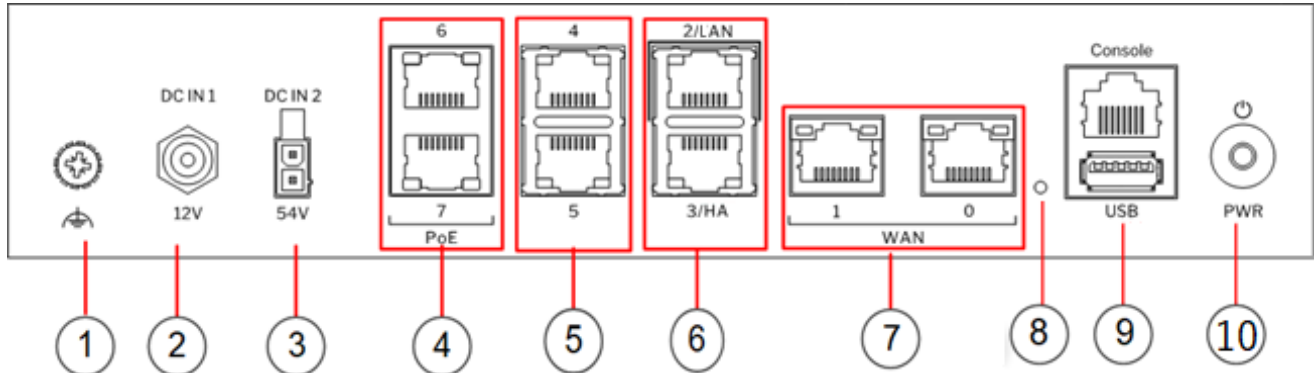

- 1 Grounding point
- 2 Power connector DC IN 1 — Provides 12V DC power for the appliance.
- 3 Power connector DC IN 2 — Optionally provides 54V DC power for the power over Ethernet (PoE) ports.



Note

PoE is an optional feature. A power adapter and power cable for PoE are not included with the delivery. To use PoE, you must purchase them separately.

- 4 Fixed Ethernet ports 6 and 7 from top to bottom.
When a power adapter is connected to power connector DC IN 2, fixed Ethernet ports 6 and 7 provide power over the Ethernet cable for other devices that are compatible with the 802.3at standard. PoE on these ports is active and uses LLDP for power negotiation.
- 5 Fixed Ethernet ports 4 and 5 from top to bottom.
- 6 Fixed Ethernet ports 2 and 3 from top to bottom.
If you use the appliance in an NGFW Engine cluster, use fixed Ethernet port 3 for the heartbeat connection between the nodes.
- 7 Fixed Ethernet ports 1 and 0 from left to right.
Ethernet ports 1 and 0 are intended for the WAN connection.

- 8 Reset button.



Note

The Reset button functionality is only supported on engine version 7.0.1 or later.

- 9 Console port (speed 115,200 bps) and USB port
- 10 Power button.

Model N120W features

The figures and tables show the components and features of the N120W (APP-120C1) appliance.

Front panel

This panel has the following parts.

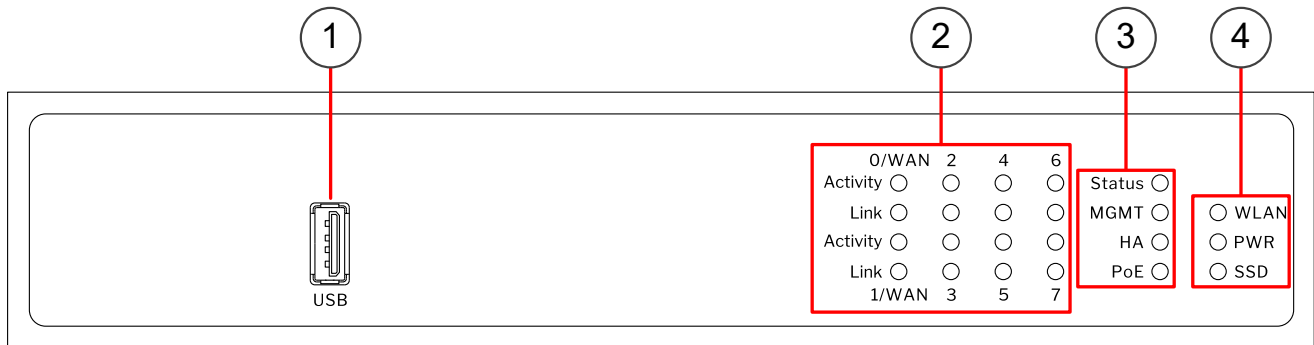

- 1 USB port
- 2 Indicators for Ethernet interface port activity and link status
- 3 Indicators for status, management (MGMT), high availability (HA), and power over Ethernet (PoE)
- 4 Indicators for wireless LAN (WLAN) connectivity, power (PWR), and disk activity (SSD)

Back panel

This panel has the following parts.

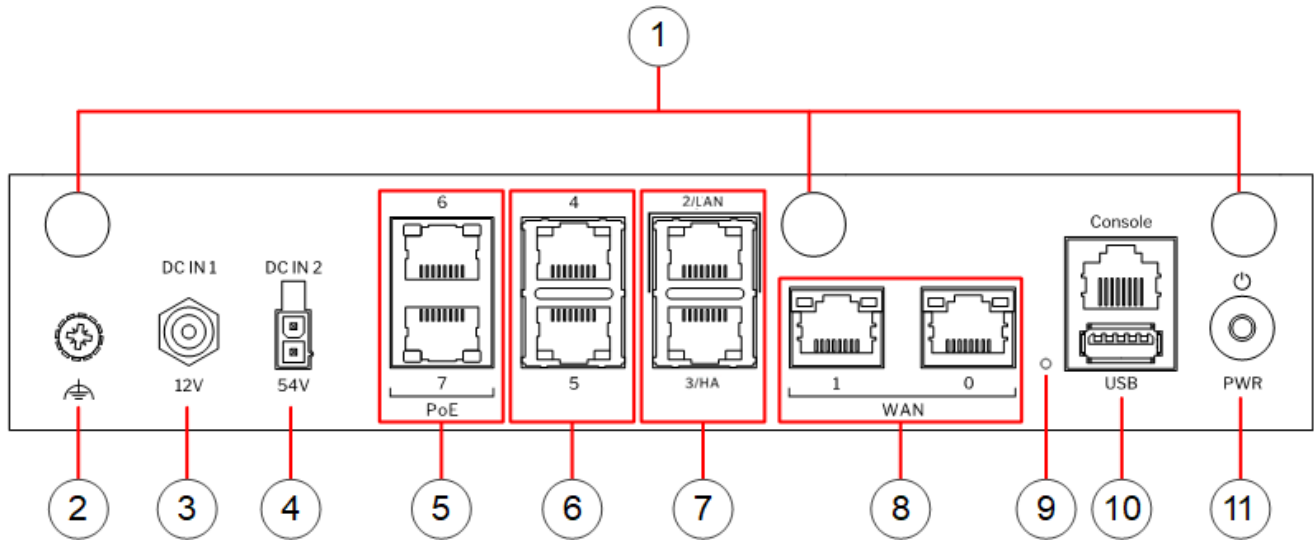

- 1 Wireless LAN antenna connectors
- 2 Grounding point
- 3 Power connector DC IN 1 — Provides 12V DC power for the appliance.
- 4 Power connector DC IN 2 — Optionally provides 54V DC power for the power over Ethernet (PoE) ports.



Note

PoE is an optional feature. A power adapter and power cable for PoE are not included with the delivery. To use PoE, you must purchase them separately.

- 5 Fixed Ethernet ports 6 and 7 from top to bottom.
When a power adapter is connected to power connector DC IN 2, fixed Ethernet ports 6 and 7 provide power over the Ethernet cable for other devices that are compatible with the 802.3at standard. PoE on these ports is active and uses LLDP for power negotiation.
- 6 Fixed Ethernet ports 4 and 5 from top to bottom.
- 7 Fixed Ethernet ports 2 and 3 from top to bottom.
If you use the appliance in an NGFW Engine cluster, use fixed Ethernet port 3 for the heartbeat connection between the nodes.
- 8 Fixed Ethernet ports 1 and 0 from left to right.
Ethernet ports 1 and 0 are intended for the WAN connection.

- 9 Reset button.



Note

The Reset button functionality is only supported on engine version 7.0.1 or later.

- 10 Console port (speed 115,200 bps) and USB port
- 11 Power button.

Model N120WL features

The figures and tables show the components and features of the N120WL appliance.

Front panel

This panel has the following parts.

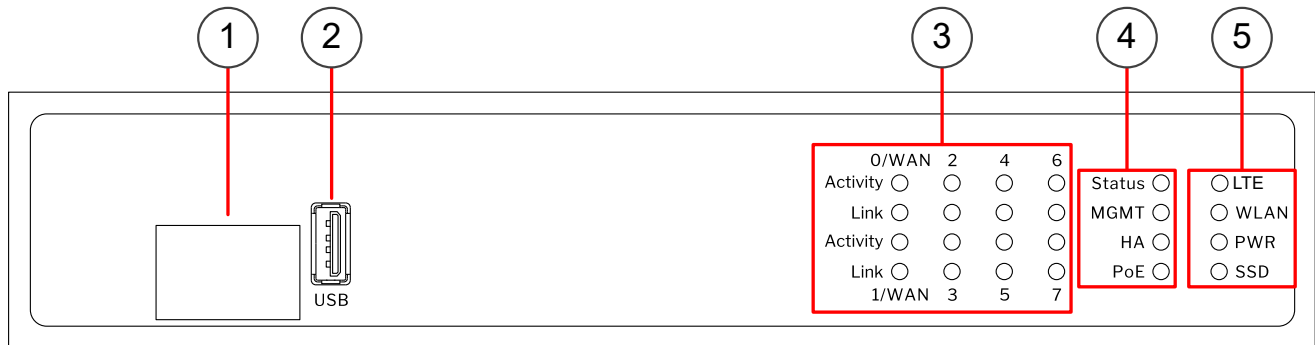

- 1 SIM card slot
- 2 USB port
- 3 Indicators for Ethernet interface port activity and link status
- 4 Indicators for status, management (MGMT), high availability (HA), and power over Ethernet (PoE)
- 5 Indicators for LTE, wireless LAN (WLAN) connectivity, power (PWR), and disk activity (SSD)

Back panel

This panel has the following parts.

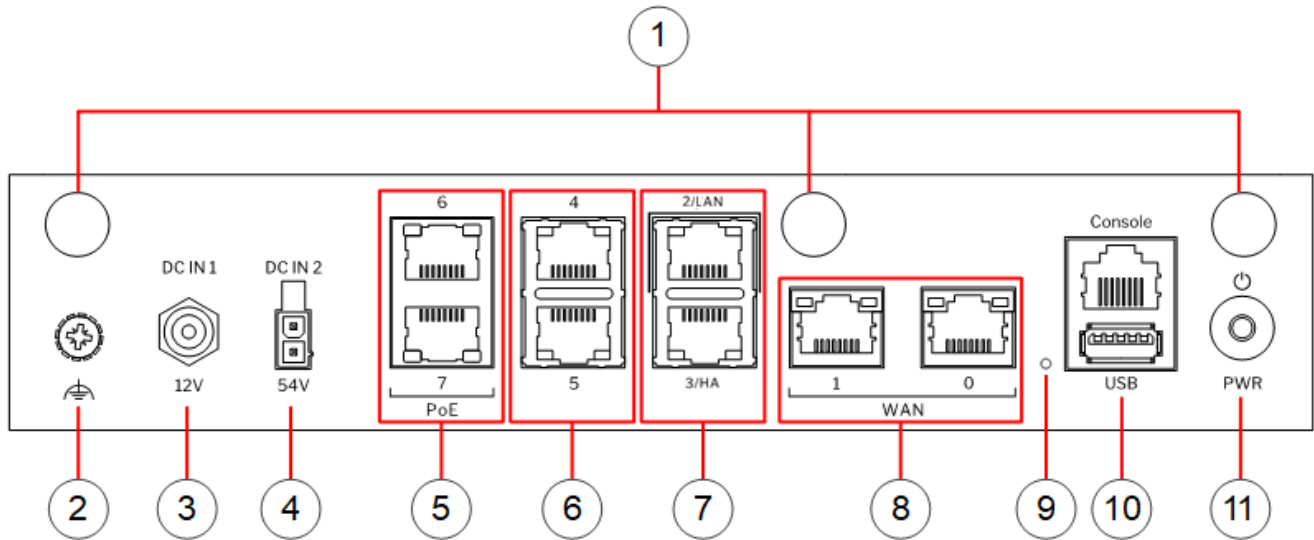

- 1 Wireless LAN antenna connectors
- 2 Grounding point
- 3 Power connector DC IN 1 — Provides 12V DC power for the appliance.
- 4 Power connector DC IN 2 — Optionally provides 54V DC power for the power over Ethernet (PoE) ports.



Note

PoE is an optional feature. A power adapter and power cable for PoE are not included with the delivery. To use PoE, you must purchase them separately.

- 5 Fixed Ethernet ports 6 and 7 from top to bottom.
When a power adapter is connected to power connector DC IN 2, fixed Ethernet ports 6 and 7 provide power over the Ethernet cable for other devices that are compatible with the 802.3at standard. PoE on these ports is active and uses LLDP for power negotiation.
- 6 Fixed Ethernet ports 4 and 5 from top to bottom.
- 7 Fixed Ethernet ports 2 and 3 from top to bottom.
If you use the appliance in an NGFW Engine cluster, use fixed Ethernet port 3 for the heartbeat connection between the nodes.
- 8 Fixed Ethernet ports 1 and 0 from left to right.
Ethernet ports 1 and 0 are intended for the WAN connection.

- 9 Reset button.



Note

The Reset button functionality is only supported on engine version 7.0.1 or later.

- 10 Console port (speed 115,200 bps) and USB port
- 11 Power button.

Side panel

This panel has the following parts.

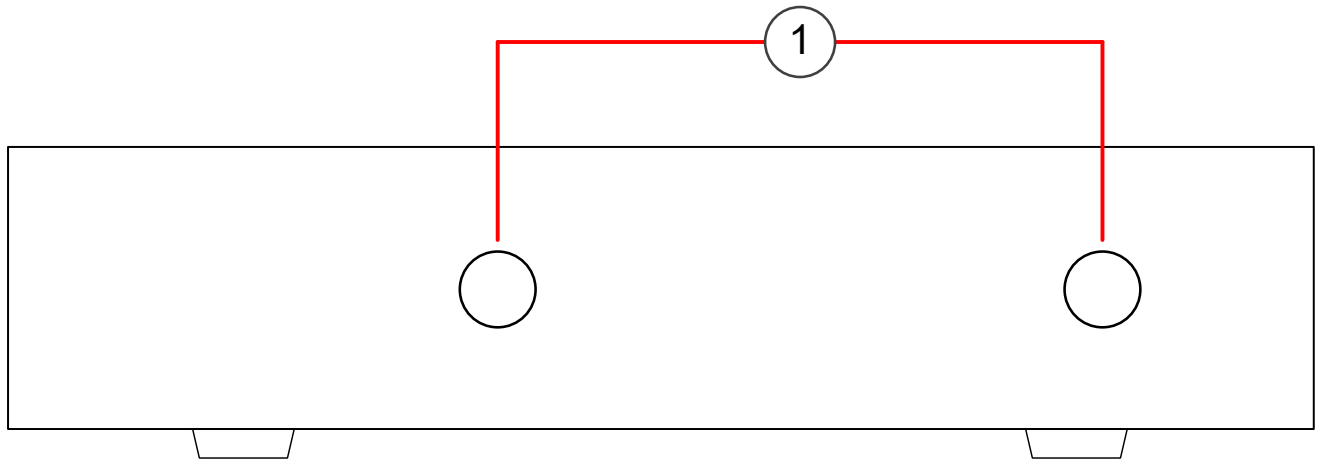

1 LTE antenna connector (two on each side)



Important

There are vents on the sides of the appliance. Keep other objects at least 100mm (4 inches) away from the appliance to ensure good air flow. Do not stack appliances.

Model N120L and N125L features

The figures and tables show the components and features of the N120L and N125L appliance.

Front panel

This panel has the following parts.



- 1 SIM card slot
- 2 USB port
- 3 Indicators for Ethernet interface port activity and link status
- 4 Indicators for status, management (MGMT), high availability (HA), and power over Ethernet (PoE)
- 5 Indicators for LTE/5G signal strength, power (PWR) and disk activity (SSD)

Back panel

This panel has the following parts.

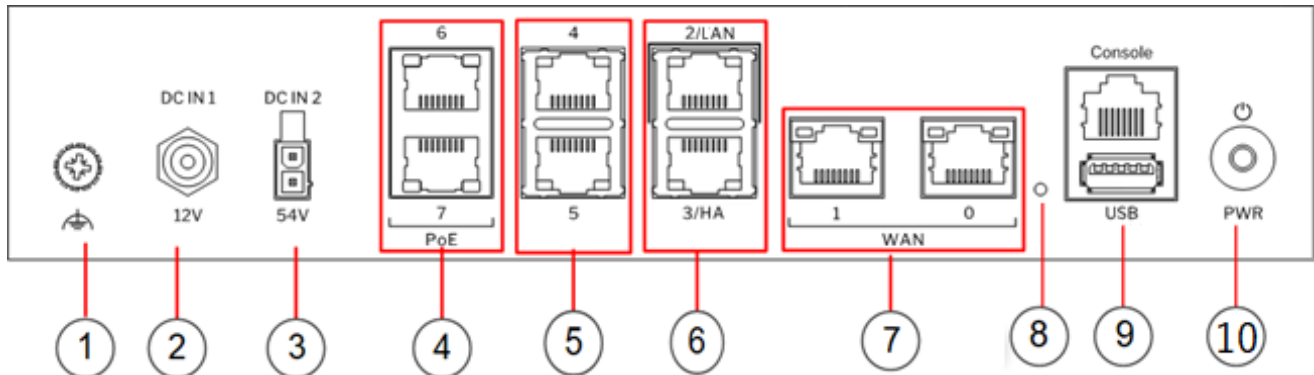

- 1 Grounding point
- 2 Power connector DC IN 1 — Provides 12V DC power for the appliance.
- 3 Power connector DC IN 2 — Optionally provides 54V DC power for the power over Ethernet (PoE) ports.



Note

PoE is an optional feature. A power adapter and power cable for PoE are not included with the delivery. To use PoE, you must purchase them separately.

- 4 Fixed Ethernet ports 6 and 7 from top to bottom.
When a power adapter is connected to power connector DC IN 2, fixed Ethernet ports 6 and 7 provide power over the Ethernet cable for other devices that are compatible with the 802.3at standard. PoE on these ports is active and uses LLDP for power negotiation.
- 5 Fixed Ethernet ports 4 and 5 from top to bottom.
- 6 Fixed Ethernet ports 2 and 3 from top to bottom.
If you use the appliance in an NGFW Engine cluster, use fixed Ethernet port 3 for the heartbeat connection between the nodes.
- 7 Fixed Ethernet ports 1 and 0 from left to right.
Ethernet ports 1 and 0 are intended for the WAN connection.

- 8 Reset button.



Note

The Reset button functionality is only supported on engine version 7.0.1 or later.

- 9 Console port (speed 115,200 bps) and USB port
- 10 Power button.

Side panel

This panel has the following parts.

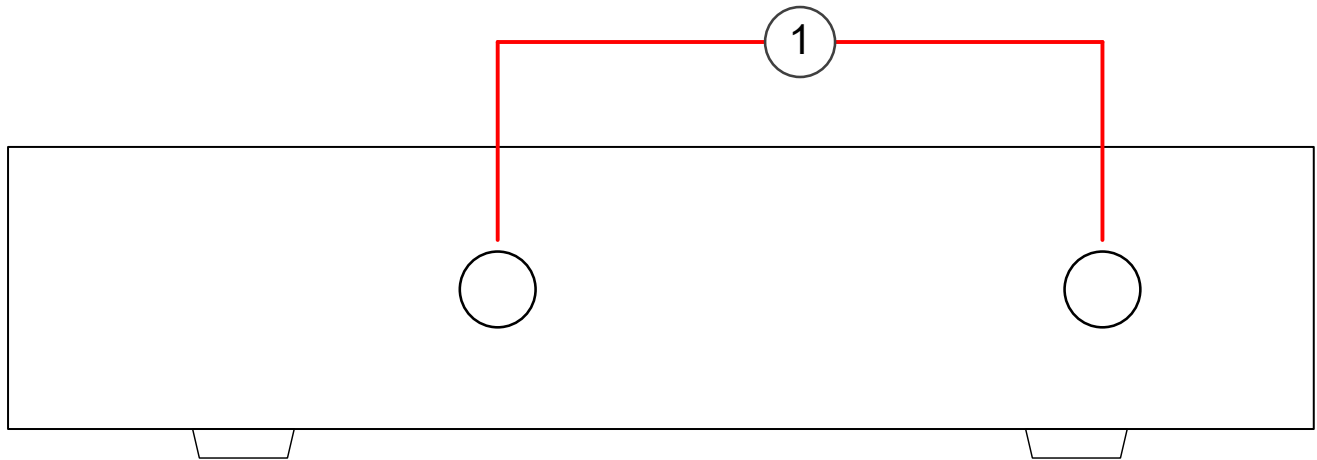

- 1 LTE antenna connector (two on each side)



Important

There are vents on the sides of the appliance. Keep other objects at least 100mm (4 inches) away from the appliance to ensure good air flow. Do not stack appliances.

Indicator lights

Indicator lights show the status of the appliance and any fixed Ethernet ports.

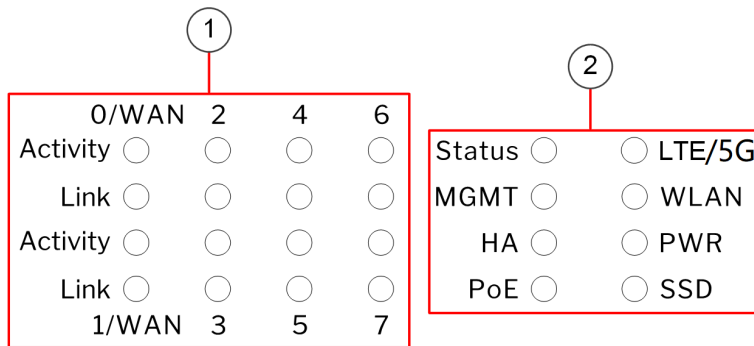

- 1 Ethernet port indicators
- 2 Status indicators

Indicator	Color	Description
Activity/ link status light for each Ethernet port (Activity)	Unlit	No link.
	Green	Link OK. Flashes on activity.

Indicator	Color	Description
Link speed light for each Ethernet port (Link)	Unlit	10 Mbps link.
	Amber	100 Mbps link.
	Green	1 Gbps or 2.5 Gbps link.  Note The ports that are 2.5 Gbps capable are 0, 1, 6 and 7.
Status	Unlit	The initial configuration has not yet been generated.
	Amber	Flashes while initial contact is being established. Steady amber when initial contact has been established, but the NGFW Engine is offline. Alternates with green when the NGFW Engine is in the standby state.
	Green	Flashes when initial contact is established, but a policy has not been installed. Steady green when the NGFW Engine is online.
MGMT	Unlit	The NGFW Engine has made initial contact but no policy is yet installed.
	Green	Flashes when the NGFW Engine tries to make initial contact or when the NGFW Engine is reconnecting to the Log Server. Steady green when initial contact with the Management Server has been made, the management connection has been established, and a policy has been installed.
HA	Unlit	The NGFW Engine does not have a clustering configuration.
	Green	The NGFW Engine has a clustering configuration.
PoE	Unlit	There is no power feed to any of the Ethernet ports that support power over Ethernet (PoE).
	Green	Power feed is active on at least one of the Ethernet ports that support PoE.
LTE/5G (N120WL, N120L and N125L only)	Unlit	There is no LTE/5G connection.
	Amber	The signal strength of the LTE/5G connection is weak.
	Amber and Green	The signal strength of the LTE/5G connection is medium
	Green	The signal strength of the LTE/5G connection is good.
WLAN (N120W and N120WL only)	Unlit	No WLAN access point is available for clients to connect to. Note: This indicator is not available in N120L appliance.
	Green	A WLAN access point is available for clients to connect to. Note: This indicator is not available in N120L appliance.
PWR	Unlit	No power source is connected to the appliance.
	Green	Power is supplied to the appliance.
	Red	The appliance is in a standby state.
SSD	Green	Flashes on disk activity.

Ethernet port indicators

Ethernet port indicators show the status and speed of the network ports.

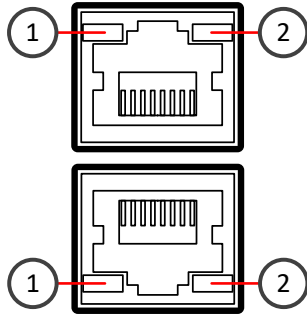

- 1 Activity/link indicator
- 2 Link speed indicator

Indicator	Color	Description
Activity/link indicator	Green	Steady when link is present. Flashes on activity.
	Unlit	No link.
Link speed indicator	Unlit	10 Mbps link.
	Amber	100 Mbps link.
	Green	1 Gbps link.

Precautions

The precautions provide safety guidance when working with Forcepoint appliances and electrical equipment.



CAUTION

Forcepoint appliances cannot be serviced by end users. Never open the appliance covers for any reason. Doing so can lead to serious injury and void the hardware warranty.

For additional safety information, see the *Forcepoint Product Safety and Regulatory Compliance Guide*.

General safety precautions

Read the safety information and follow these rules to ensure general safety whenever you are working with electronic equipment.

- Keep the area around the appliance clean and free of clutter.
- Use a regulating uninterruptible power supply (UPS) to keep your system operating during power failures and to protect the appliance from power surges and voltage spikes.
- If you need to turn off or unplug the appliance, always wait at least five seconds before turning on or plugging in the appliance again.

Operating precautions

Follow these precautions when operating the appliance.

- Do not open the power adapter casing. Only the manufacturer's qualified technician can access and service power adapters.
- For this specific appliance model, it is recommended to use the power supply that is shipped with the appliance or additional spare unit from Foreceptoint.

WLAN precautions for models N120W and N120WL

Data traffic by a wireless connection might allow unauthorized third parties to receive data. Take the necessary steps to secure your radio network.

See <https://www.wi-fi.org> for information about securing your WLAN.

Restrictions and requirements might apply for authorizing wireless devices. Check with your local authorities for additional information.

Electrical safety precautions

Follow basic electrical safety precautions to protect yourself from harm and the appliance from damage.

- Know the locations of the power on/off button and the emergency turn-off switch, disconnection switch, or electrical outlet for the room. If an electrical accident occurs, you can quickly turn off power to the system.
- When working with high-voltage components, do not work alone.
- When working with electrical equipment that is turned on, use only one hand. This is to avoid making a complete circuit, which causes an electric shock. Use extreme caution when using metal tools, which can easily damage any electrical components or circuit boards the tools come into contact with.
- Do not use mats designed to decrease electrostatic discharge as protection from electric shock. Instead, use rubber mats that have been designed as electrical insulators.
- If the power supply cable includes a grounding plug, the plug must be plugged into a grounded electrical outlet.
- Use only the power cable or cables supplied with the appliance.
- Outdoor devices connected to the appliance must be placed on the same building as where the appliance is located. The devices must also be installed so they are protected from lightning strikes, for example under a roof.



Note

Standby power is supplied to the appliance even when the appliance is turned off.

AC power supply safety precautions

The appliance power inlet is the disconnect device on the appliance.

Install the appliance

There are several tasks that must be completed before the appliance is installed.

These tasks and the installation of the appliance might be done by the same person or by different persons:

- The Security Management Center (SMC) administrator is responsible for the tasks that are needed before the appliance is installed.
- The on-site installer is responsible for installing the appliance.

For more information, see the *Forcepoint Next Generation Firewall Installation Guide*.

To prepare for the appliance installation, the SMC administrator must do the following:

- 1) If the SMC has not yet been installed, install the SMC.



Important

Do not install the SMC on the NGFW appliance.

The SMC can manage many NGFW appliances.

- 2) In the Management Client component of the SMC, create and configure the NGFW Engine element that represents the appliance.
- 3) In the Management Client component of the SMC, save the initial configuration.
The SMC administrator must either:
 - Upload the initial configuration to the Installation Server for plug-and-play configuration of the appliance.



Note

There are additional requirements for plug-and play configuration. See Knowledge Base article [9662](#).

- Give the on-site installer a USB drive that contains an initial configuration file for each appliance.

The on-site installer must do the following:

- 1) Inspect the appliance, delivery box, and all components included in the shipment.



Important

Do not use damaged appliances or components.

- 2) Connect all necessary power, network cables and other components, and then press the power button to turn on the appliance.

If the plug-and-play configuration method is not used, the on-site installer must insert the USB drive that contains the initial configuration files to configure the NGFW Engine software to an USB port before the appliance is turned on.

By default, only one power supply is shipped with the appliance. However, an additional power supply can be ordered and connected for redundancy.

Power supply monitoring is automatically enabled when the appliance is powered on using two power adapters. When power supply monitoring is enabled and only one power supply is present, a warning is provided in SMC engine info status pane.

- 3) When you have finished installing the appliance, inform the SMC administrator so that the administrator can check the status of the appliance in the Management Client.

Insert a SIM card for models N120WL, N120L and N125L

To use the LTE modem in N120WL, N120L and N125L models, you must insert a separately-purchased SIM card into the appliance.

Before you begin

Before you insert or replace a SIM card, turn off the appliance.

The SIM card must be a Nano-SIM card. Full-sized SIM cards, Mini-SIM cards, and Micro-SIM cards are not supported.



Note

To use the mobile connection for plug-and-play configuration, make sure that the PIN code query is disabled on the SIM card. For more information, see Knowledge Base article [17249](#).

Steps

- 1) To release the SIM card tray, gently push the SIM card tray.
- 2) Remove the SIM card tray.
- 3) With the SIM card contacts facing down, insert the SMC card into the tray, then gently push the tray back into the SIM card slot.

Attach antennas for models N120W, N120WL, N120L and N125L

Attach the antennas included in the delivery to the appliance.

Before you begin

Before you attach or replace the antennas, you must turn off the appliance.

The following antennas are included with the delivery:

- Wireless LAN antennas — 3 pieces, round whip antennas
- LTE antennas — 4 pieces, flat whip (only for models N120WL and N120L)

**CAUTION**

To avoid damaging the antennas or the appliance, make sure to attach the correct antennas to the correct connectors. Wireless LAN antennas have recessed connectors. LTE antennas have protruding connectors.

Steps

- 1) Locate the antennas included in the appliance delivery.
- 2) Attach the wireless LAN antennas to the connectors on the back panel of the appliance.
- 3) Attach the LTE antennas to the connectors on the side panels of the appliance (only for models N120WL and N120L).
- 4) Tighten the knurled nuts at the base of the antennas to secure them firmly to the appliance.
- 5) While holding the base of the antennas, position the antennas.

Mount the N120, N120W, N120WL, N120L, or N125L appliance on a wall

You can optionally mount the N120, N120W, N120WL, N120L, or N125L appliance on a wall.

**Important**

There are vents on the sides of the appliance. Keep other objects at least 100mm (4 inches) away from the appliance to ensure good air flow. Do not stack appliances.

Mounting the appliance on a wall has the following requirements:

- You can mount the appliance in a horizontal orientation only with the connectors for the cables facing down.
- The distance between the holes that you drill for the appliance in the wall must be 120mm (4.7 inches).
- Depending on the wall material, you might need to insert nylon plugs into the mounting holes that you drill for the appliance. No nylon plugs are supplied with the appliance.
- Two flat undercut screws are required. No screws are supplied with the appliance.
The diameter of the screw heads must be 5.5mm (7/32 inch) and the thickness of the screw heads must be 2mm (5/64 inch).

Select screws that are suitable for the wall material and long enough to provide a firm mounting point for the appliance. If you have attached the four provided rubber feet to the bottom of the appliance, make sure that the screws are long enough to provide a firm mounting point for the appliance with the feet attached.

Make sure that the heads of the screws fit into the mounting holes on the bottom of the appliance before you drill the mounting holes in the wall.

Steps

- 1) Drill two holes 120mm (4.7 inches) apart in the wall in a horizontal orientation.
Make sure that you leave enough clearance around the appliance.

- 2) If required, insert nylon plugs into the holes.
- 3) Insert the two screws into the holes and tighten the screws.
Make sure that the screws are protruding from the wall to provide a firm mounting point for the appliance.
- 4) Align the mounting holes on the appliance with the screws, then place the appliance on the screws so that the cables are below the appliance.
After the appliance is mounted on the wall and you have connected the cables, do not pull on the cables.



CAUTION

If you need to disconnect any cables after the appliance is mounted on the wall, hold the appliance in place while you disconnect the cables.

Rack-Mount the N120, N120W, N120WL, N120L, or N125L appliance

The rack-mounting procedure varies depending on the type of rack unit. If needed, see the documentation for your rack unit.

Instead of rack-mounting the appliance, you can also place the appliance on a flat surface, such as a desk or shelf.

How to determine the placement of each component in the rack:

- Install the heaviest components on the bottom of the rack first. Install components from the bottom to the top.
- The appliance must be connected to a grounded power outlet.
- Use a UPS to protect the appliance from power surges and voltage spikes, and to keep your system operating if there is a power failure.
- To maintain proper cooling, always keep the front door of the rack and all panels and components on the appliances closed when not servicing.

Install the appliance in a rack

Use the rack-mounting brackets to secure the appliance in the rack.

Before you begin

The brackets and screws are not included by default. You can order them separately.

Steps

- 1) Locate the brackets for the rack installation.



Note

The bracket delivery includes two rack-mounting brackets.

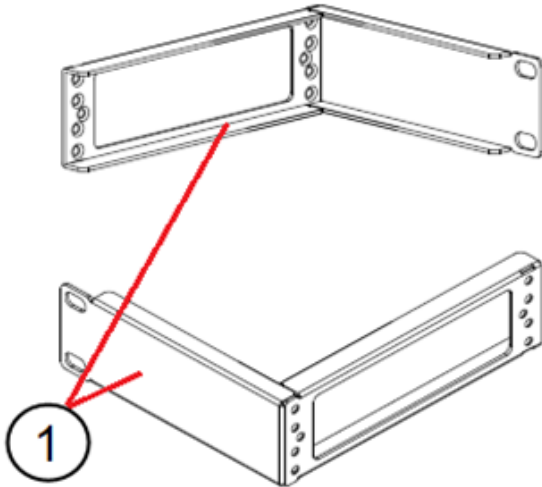

- 1 Rack-mounting brackets.

- 2) Unscrew the 3 screws from the left panel and the right panel of the appliance.



CAUTION

Do not reuse these screws for attaching the brackets. The screws are not long enough to properly attach the brackets.

- 3) Attach the brackets to the left and right panel of the appliance with 3 screws through the holes in each bracket.



Note

The rack-mounting bracket face that has two screw holes, must be aligned only with the back panel or front panel of the appliance.

- 4) Attach the bracket to the rack with two screws through the holes in the front of the appliance, and with two screws through the holes in the back of the appliance.

Connect the cables

Connect the network and power cables.

Use at least CAT5e-rated cables for gigabit networks.

Network interfaces at both ends of each cable must have identical speed and duplex settings. These settings include the automatic negotiation setting. If one end of the cable uses autonegotiation, the other end must also

use autonegotiation. Gigabit standards require interfaces to use autonegotiation. Fixed settings are not allowed at gigabit speeds.

Connect network cables

Ethernet ports are mapped to interface IDs during the initial configuration. Determine which Ethernet ports to use for connecting to your networks.

Steps

- 1) Connect network cables to the Ethernet ports.
If you use the plug-and-play configuration method for a single NGFW appliance, the appliance uses Ethernet port 0 to contact the Installation Server.
If the appliance is a node in an NGFW Engine cluster, connect the cable for the heartbeat connection between the nodes to Ethernet port 2.
Web based NGFW Configuration Wizard runs on port labeled as LAN (port 2).
- 2) Connect the cables to the ports that are used for the integrated switch.

Related concepts

[How the integrated switch works](#) on page 22

Connect the power adapters

Use the power cable to plug in the appliance.



Note

We recommend using a UPS to ensure continuous operation and minimize the risk of damage to the appliance in case of sudden loss of power.

Steps

- 1) Attach a suitable power plug for your region to the 12V power adapter for the appliance.
Standard power plugs for several regions are included with the delivery.
- 2) Connect the 12V power adapter for the appliance to the DC IN power connector on the back of the appliance.
- 3) (Optional) To use PoE to provide power for other devices, connect the 54V power adapter for PoE to the DC IN 2 power connector on the back of the appliance.



Note

PoE is an optional feature. A power adapter and power cable for PoE are not included with the delivery. To use PoE, you must purchase them separately.

- 4) Plug the power connector or power connectors into a high-quality power strip that offers protection from electrical noise and power surges.

Next steps

To use PoE to provide power for other devices that are compatible with the 802.3at standard, connect the devices to Ethernet ports 6 or 7 on the back of the appliance.

Port settings for plug-and-play configuration method

If you use the plug-and-play configuration method for a single NGFW appliance, the appliance uses Ethernet port 0 to contact the Installation Server.

On the N120WL model, the appliance uses modem interface 0 to contact the Installation Server. If modem interface 0 is not available, Ethernet port 0 is used. To use the mobile connection for plug-and-play configuration, make sure that the PIN code query is disabled on the SIM card.

To use the plug-and-play configuration method, the interface that corresponds to Ethernet port 0 in the initial configuration must have a dynamic IPv4 address.

How the integrated switch works

An integrated switch represents the switch functionality on purpose-built Forcepoint NGFW appliances. Integrated switches eliminate the need for an external switch device and reduce costs and clutter.

This Forcepoint NGFW appliance has a software integrated switch. You can configure one or more integrated switches. You can configure one port group on each integrated switch. The Forcepoint NGFW engine does not inspect traffic between ports in the same port group.



Note

You can only use the integrated switch if the appliance has been configured as a Single Firewall. You cannot use the integrated switch as an external switch device without Forcepoint NGFW properly configured and running.

When the Forcepoint NGFW engine is in the initial configuration state and no configuration has been saved to the integrated switch, there are no ports in the integrated switch and the integrated switch does not yet route traffic. After a configuration has been saved, traffic is allowed between ports in the same port group according to the configuration, even if you reboot the appliance.

If you turn off the appliance, traffic between the ports in the same port group is interrupted. The last saved port group configuration is automatically applied to the appliance when the appliance is turned on again.



Note

The ports in the integrated switch do not support VLAN tagging or PPPoE. You cannot use ports on the integrated switch as the control interface.

For more information, see the *Forcepoint Next Generation Firewall Installation Guide* and the *Forcepoint Next Generation Firewall Product Guide*.

Maintenance

Some Forcepoint NGFW appliances ship with replaceable components.

Restoring appliance settings

You can use one of the following methods to restore the appliance settings to the factory default settings:



Note

Restoring appliance settings does not impact the current software version. The software version will remain as the latest installed version.

- To initiate the restore of the appliance settings if the appliance is connected to the management client, do the following:
 - 1) From the management client in the SMC, select **Configuration**.
 - 2) Browse to **Engine**.
 - 3) Right-click an engine for which you want to restore the appliance settings to factory default settings.
 - 4) Select **Commands > Reset to Factory Settings**.
- To initiate and complete the reset without using appliance console, do the following:
 - 1) Connect to the appliance using SSH.
 - 2) Run the following CLI command to restore the factory default settings on the engine:

```
sg-clear-all --fast
```

- To initiate the restore of appliance settings from the local console, select **Boot > System restore**.
- To initiate restoring of appliance settings by using the **Reset** button, press and hold the **Reset** button for few seconds until you can see the red colored power LEDs.

**Note**

- 1) This method can only work, if the appliance is powered on and must have run for at least 2 minutes.
- 2) The **Reset** button is present right next to the **Console** and **USB** ports. For example, the **Reset** button can be pressed by using a small pen tip.
- 3) The system restore is ready, when the appliance is set to standby powered state (power off). The standby powered state is indicated by red colored power LEDs.
- 4) If the serial console is in use, the following messages are displayed in the console:
 - a) Factory default settings restored
 - b) reboot: Power down

This indicates that the system restore is completed successfully and is ready to use.

Turn off the appliance

Most Forcepoint NGFW appliance hardware components are not hot-swappable. Turn off the appliance from the NGFW Engine command line.

**Tip**

The SMC administrator can also turn off the appliance remotely using the Management Client. For more information, see the *Forcepoint Next Generation Firewall Product Guide*.

Steps

- 1) Connect to the NGFW Engine command line.
Depending on the appliance type, use one of the following options:
 - Connect a computer running a terminal emulator program to the appliance console port, then press **Enter**.
 - Connect using SSH.

**Note**

SSH access is not enabled by default.

- Connect a keyboard to a USB port and a monitor to the VGA port, then press **Enter**.
- 2) Enter the logon credentials.
The user name is `root` and the password is the one you set for the appliance.
 - 3) Enter the following command:

```
halt
```

- 4) Wait until the power indicator light turns red or is unlit, then unplug all power cables from the appliance.

Replace the SIM card for models N120WL, N120L, and N125L

You might need to replace the SIM card for the LTE modem in the models N120WL, N120L, and N125L if you change mobile operators, or if you get a new SIM card from the same mobile operator.

Before you begin

Before you insert or replace a SIM card, turn off the appliance.

The SIM card must be a Nano-SIM card. Full-sized SIM cards, Mini-SIM cards, and Micro-SIM cards are not supported.

Steps

- 1) To release the SIM card tray, gently push the SIM card tray.
- 2) Remove the SIM card tray.
- 3) Remove the old SIM card from the tray.
- 4) With the SIM card contacts facing down, insert the SMC card into the tray, then gently push the tray back into the SIM card slot.
- 5) Press the power button to start up the appliance.
- 6) If PIN code query is enabled on the new SIM card and the modem interface is used for the management connection, change the PIN code.



Note

If the PIN code for the new SIM card is the same as the PIN code for the old SIM card, it is not necessary to change the PIN code.

- a) Log on to the appliance.
The user name is `root` and the password is the one you set for the appliance.

- b) To start the NGFW Configuration Wizard, enter the following command:

```
sg-reconfigure
```

- c) In the NGFW Configuration Wizard, enter the PIN code.

- d) To restart the appliance, enter the following command:

```
reboot
```

- e) In the Management Client, enter the PIN code in the modem interface properties, then refresh the policy on the NGFW Engine.



Note

Tasks in the Management Client are intended to be done by the SMC administrator.

Power over Ethernet

The N120W, N120WL, N120, N120L, and N125L models complies with the PoE+ (802.3at) standard and can provide a maximum power consumption of 25.5 Watts to each of the attached devices.

Compliance information

Forcepoint NGFW appliances that have wireless support are in compliance with certain EU directives and FCC standards for wireless devices intended for home and office use.

This information is valid for all dual band products (2.4 GHz, IEEE 802.11b/g/n, and 5 GHz, IEEE 802.11a/n/ac).

The supported channels and frequencies are listed by country in the Management Client. The wireless configuration is transferred to the appliance when you install the policy on the NGFW Engine.

EU Directives

This appliance is in compliance with:

- EMC directive 2014/30/EU
- LVD directive 2014/35/EU
- RED directive 2014/53/EU

To view the EU DoC, refer to the [link](#).

The frequencies and maximum transmitted power in the EU are:

- For model N120W (APP-120C1) and N120WL (APP-120C2):
 - 2.41–2.47 GHz: 18.86 dBm (EIRP)
 - 5.15–5.25 GHz: 21.62 dBm (EIRP)
 - 5.95–6.41 GHz: LPI: 20.75 dBm (EIRP)
 - 5.95–6.41 GHz: VLP: 11.51 dBm (EIRP)
- For model N125L (APP-120C5):
 - LTE: 25dBm
 - 5G NR: 26dBm

Operations in the 5150–5250 MHz band are restricted to indoor usage only (For APP-120C1, N120WL).

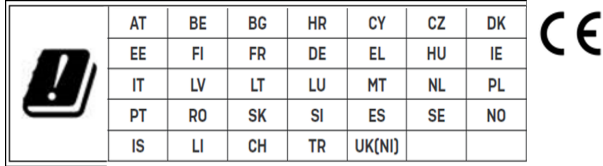

FCC Standards

This appliance is in compliance with [FCC Part 15](#).

Applied technologies

The appliance uses these technologies.

- **Safety** — Dual band products
- **Electromagnetic Compatibility (EMC)** — Dual band products

National restrictions and requirements for authorization

These appliances can be operated within FCC DFS2 band or ETSI/EC DFS band, or other countries that regulate or plan to regulate mid-5 GHz band.

The usage of mid-5 GHz band is subject to the regulatory approval alone with the resided devices.

The requirements for any country or area might change. We recommend that you check with your local authorities for the latest status of national requirements for 2.4 GHz and 5 GHz wireless LANs.

Industry Canada statement

1 This device complies with Industry Canada license-exempt RSS standard(s). Operation is subject to the following two conditions:

- 1) this device may not cause interference, and
- 2) this device must accept any interference, including interference that may cause undesired operation of the device.

1 Le présent appareil est conforme aux CNR d'Industrie Canada applicables aux appareils radio exempts de licence. L'exploitation est autorisée aux deux conditions suivantes:

- 1) l'appareil ne doit pas produire de brouillage, et
- 2) l'utilisateur de l'appareil doit accepter tout brouillage radioélectrique subi, même si le brouillage est susceptible d'en compromettre le fonctionnement.

2 This Class B digital apparatus complies with Canadian ICES-003.

2 Cet appareil numérique de la classe B est conforme à la norme NMB-003 du Canada.

3 This device and its antenna(s) must not be co-located or operating in conjunction with any other antenna or transmitter, except tested built-in radios.

3 Cet appareil et son antenne ne doivent pas être situés ou fonctionner en conjonction avec une autre antenne ou un autre émetteur, exception faites des radios intégrées qui ont été testées.

4 The County Code Selection feature is disabled for products marketed in the US/ Canada.

4 La fonction de sélection de l'indicatif du pays est désactivée pour les produits commercialisés aux États-Unis et au Canada.

This radio transmitter (identify the device by certification number) has been approved by Industry Canada to operate with the antenna types listed below with the maximum permissible gain indicated. Antenna types not included in this list, having a gain greater than the maximum gain indicated for that type, are strictly prohibited for use with this device.

Cet émetteur radio (identifier l'appareil par numéro de certification) a été approuvé par l'industrie Canada pour fonctionner avec les types d'antenne énumérés ci-dessous avec le gain maximum admissible indiqué. Types d'antennes non inclus dans cette liste, ayant un gain supérieur au gain maximum indiqué pour cette type, sont strictement interdits pour une utilisation avec cet appareil.

List of antenna information (For APP-120C1, N120WL)				Peak EIRP
Components	Frequency (MHz)	Antenna type	Brand	Main
WLAN	2400–2500	Dipole	ARISTOTLE	2.35 dBi
WLAN	5150–5925	Dipole	ARISTOTLE	3.0 dBi
WLAN	6000–7125	Dipole	ARISTOTLE	3.02 dBi

Radiation Exposure Statement:

This equipment complies with IC radiation exposure limits set forth for an uncontrolled environment. This equipment should be installed and operated with minimum distance 20cm between the radiator & your body.

Déclaration d'exposition aux radiations:

Cet équipement est conforme aux limites d'exposition aux rayonnements IC établies pour un environnement non contrôlé. Cet équipement doit être installé et utilisé avec un minimum de 20 cm de distance entre la source de rayonnement et votre corps.

Caution:

- 1) The device for operation in the band 5150–5250 MHz is only for indoor use to reduce the potential for harmful interference to co-channel mobile satellite systems;
- 2) For devices with detachable antenna(s), the maximum antenna gain permitted for devices in the band 5725-5850 MHz shall be such that the equipment still complies with the e.i.r.p. limits as appropriate;

Prudence:

- 1) les dispositifs fonctionnant dans la bande de 5 150 à 5 250 MHz sont réservés uniquement pour une utilisation à l'intérieur afin de réduire les risques de brouillage préjudiciable aux systèmes de satellites mobiles utilisant les mêmes canaux
- 2) pour les dispositifs munis d'antennes amovibles, le gain maximal d'antenne permis (pour les dispositifs utilisant la bande de 5 725 à 5 850 MHz) doit être conforme à la limite de la p.i.r.e. spécifiée, selon le cas;

Warning: Operation of transmitters in the 5.925-7.125 GHz band is prohibited for control of or communications with unmanned aircraft systems.

Avertissement: L'utilisation des émetteurs dans la bande de 5.925 à 7.125 GHz est interdite pour le contrôle ou la communication avec des systèmes d'aéronefs sans pilote.

Federal Communication Commission Interference Statement

This device complies with Part 15 of the FCC Rules. Operation is subject to the following two conditions: (1) This device may not cause harmful interference, and (2) this device must accept any interference received, including interference that may cause undesired operation.

This equipment has been tested and found to comply with the limits for a Class B digital device, pursuant to Part 15 of the FCC Rules. These limits are designed to provide reasonable protection against harmful interference in a residential installation. This equipment generates, uses and can radiate radio frequency energy and, if not installed and used in accordance with the instructions, may cause harmful interference to radio communications. However, there is no guarantee that interference will not occur in a particular installation. If this equipment does cause harmful interference to radio or television reception, which can be determined by turning the equipment off and on, the user is encouraged to try to correct the interference by one of the following measures:

- Reorient or relocate the receiving antenna.
- Increase the separation between the equipment and receiver.
- Connect the equipment into an outlet on a circuit different from that to which the receiver is connected.
- Consult the dealer or an experienced radio/TV technician for help.

FCC Caution:

- Any changes or modifications not expressly approved by the party responsible for compliance could void the user's authority to operate this equipment.
- This transmitter must not be co-located or operating in conjunction with any other antenna or transmitter.

FCC Warning: Operation of transmitters in the 5.925-7.125 GHz band is prohibited for control of or communications with unmanned aircraft systems.

Radiation Exposure Statement:

This equipment complies with FCC radiation exposure limits set forth for an uncontrolled environment. This equipment should be installed and operated with minimum distance 20cm between the radiator & your body.



Note

The country code selection is for non-US model only and is not available to all US model. Per FCC regulation, all WiFi product marketed in US must fixed to US operation channels only.

Radio frequency statement for Brazil:

Este equipamento não tem direito à proteção contra interferência prejudicial e não pode causar interferência em sistemas devidamente autorizados.

