



Next Generation Firewall

350 Series

**Models N352 (APP-352C1) and N355
(APP-355C1), Internet Security Device**

Hardware Guide

Contents

- Introduction on page 2
- Find product documentation on page 2
- N352 and N355 features on page 3
- Indicator lights on page 4
- Ethernet port indicators on page 5
- SFP port led indicators on page 6
- Precautions on page 6
- Install the appliance on page 8
- Connect the cables on page 12
- Port settings for plug-and-play configuration method on page 13
- Restoring appliance settings on page 13
- Turn off the appliance on page 14

Introduction

Thank you for choosing a Forcepoint appliance.

Familiarize yourself with the appliance ports and indicators and learn how to install the appliance safely.

Find product documentation

In the Forcepoint Customer Hub, you can find information about a released product, including product documentation, technical articles, and more.

You can get additional information and support for your product in the Forcepoint Customer Hub at <https://support.forcepoint.com>. There, you can access product documentation, release notes, Knowledge Base articles, downloads, cases, and contact information.

You might need to log on to access the Forcepoint Customer Hub. If you do not yet have credentials, create a customer account. See <https://support.forcepoint.com/s/CreateAccount>.

N352 and N355 features

The figures and tables show the appliance components and features.

Front panel

This panel has the following parts.

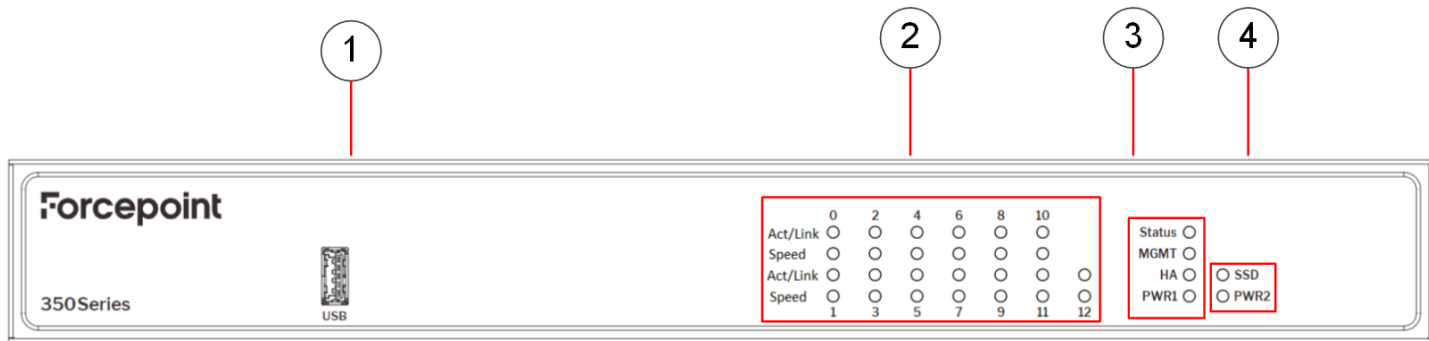

- 1 USB port.
- 2 Indicators for Ethernet interface port activity and link status.
- 3 Indicators for status, management (MGMT), high availability (HA), and power (PWR).
- 4 Indicators for power (PWR) and disk activity (SSD).

Back panel

This panel has the following parts.

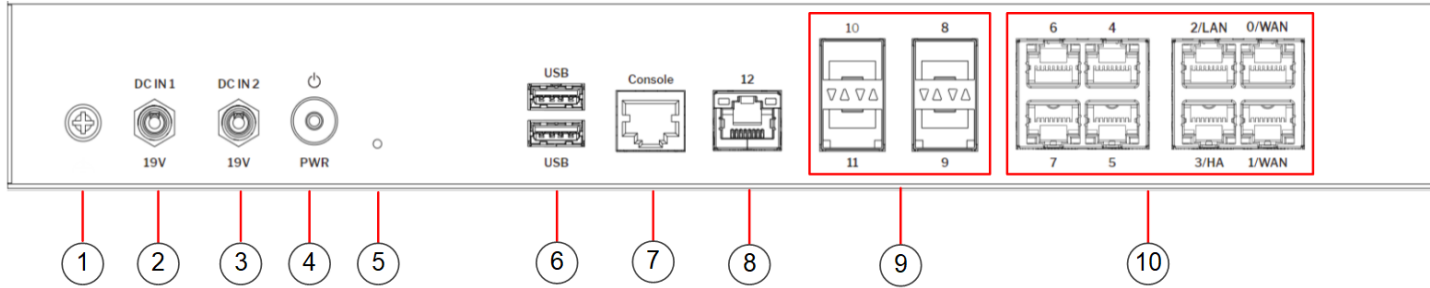

- 1 Grounding point.
- 2 Power connector DC IN 1 — Provides 19V DC power for the appliance.
- 3 Power connector DC IN 2 — Provides 19V DC power for the appliance.
- 4 Power button.
- 5 Reset button. Reset button functionality is supported from Engine version 7.0.1 onwards.
- 6 USB ports.
- 7 Console port (speed 115,200 bps).
- 8 Fixed Ethernet 2.5Gbps RJ45 port 12.
- 9 Fixed SFP+ ports 8-11 from top to bottom and right to left.
- 10 Fixed Ethernet RJ45 ports 0-7 from top to bottom and right to left.

Indicator lights

Indicator lights show the status of the appliance and any fixed Ethernet ports.

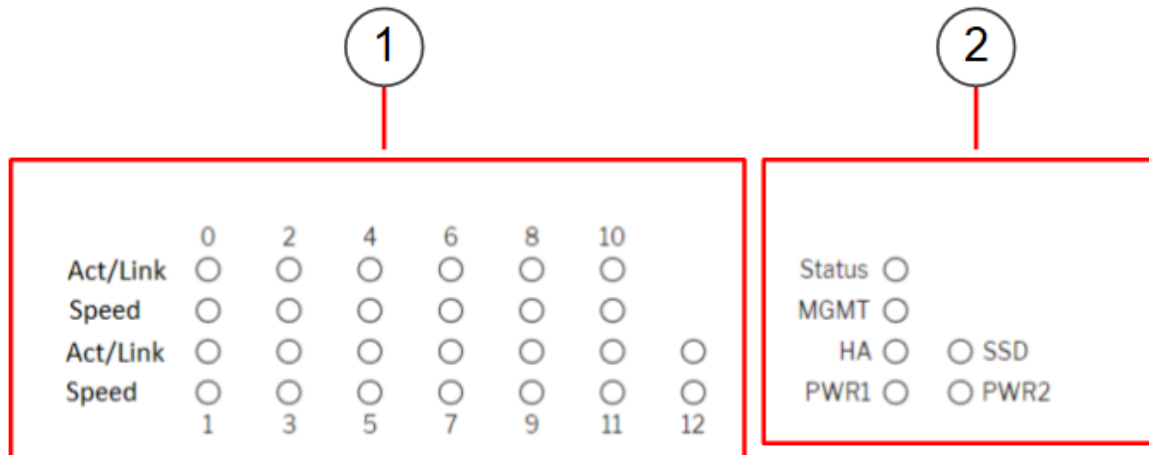

- 1 Ethernet port indicators
- 2 Status indicators

Indicator	Color	Description
Activity/link status light for each Ethernet port (Activity)	Unlit	No link.
	Green	Link OK. Flashes on activity.
Link speed light for each Ethernet port (Link)	Unlit	10 Mbps link.
	Amber	100Mbps link (ports 0-11), 100Mbps/1Gbps (port 12).
	Green	1 Gbps link (ports 0-11), 2.5Gbps (port 12).
Status	Unlit	The initial configuration has not yet been generated.
	Amber	Flashes while initial contact is being established. Steady amber when initial contact has been established, but the NGFW Engine is offline. Alternates with green when the NGFW Engine is in the standby state.
	Green	Flashes when initial contact is established, but a policy has not been installed. Steady green when the NGFW Engine is online.
MGMT	Unlit	The NGFW Engine has made initial contact but no policy is yet installed.
	Green	Flashes when the NGFW Engine tries to make initial contact or when the NGFW Engine is reconnecting to the Log Server. Steady green when initial contact with the Management Server has been made, the management connection has been established, and a policy has been installed.
HA	Unlit	The NGFW Engine does not have a clustering configuration.
SSD	Green	Flashes on disk activity.
PWR 1 and PWR 2	Unlit	No power source is connected to the appliance.
	Green	Power is supplied to the appliance.
	Red	No power source is connected to the respective connector. If both the LEDs are "Red", the appliance is in a standby powered state.

Ethernet port indicators

Ethernet port indicators show the status and speed of the network ports.

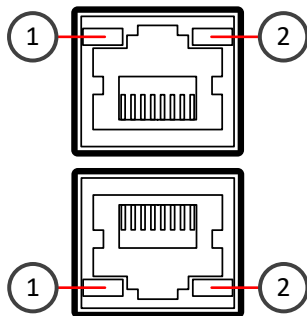

- 1 Activity/link indicator
- 2 Link speed indicator

Indicator	Color	Description
Activity/link indicator	Green	Steady when link is present. Flashes on activity.
	Unlit	No link.
Link speed indicator	Unlit	10 Mbps link.
	Amber	100 Mbps link.
	Green	1 Gbps link.

SFP port led indicators

SFP port led indicators show the status and speed of the network ports.

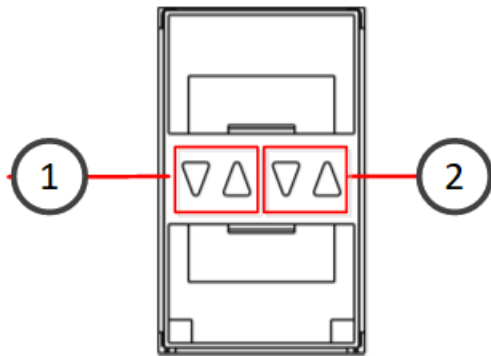

- 1 Activity/link indicator
- 2 Link speed indicator

Indicator	Color	Description
Activity/link indicator	Green	Link OK. Flashes on activity.
Link speed indicator	Unlit	1 GB link.
	Green	10 GB link.

Precautions

The precautions provide safety guidance when working with Forcepoint appliances and electrical equipment.



CAUTION

Forcepoint appliances cannot be serviced by end users. Never open the appliance covers for any reason. Doing so can lead to serious injury and void the hardware warranty.

For additional safety information, see the *Forcepoint Product Safety and Regulatory Compliance Guide*.

General safety precautions

Read the safety information and follow these rules to ensure general safety whenever you are working with electronic equipment.

- Keep the area around the appliance clean and free of clutter.
- Use a regulating uninterruptible power supply (UPS) to keep your system operating during power failures and to protect the appliance from power surges and voltage spikes.
- If you need to turn off or unplug the appliance, always wait at least five seconds before turning on or plugging in the appliance again.

Operating precautions

Follow these precautions when operating the appliance.

- Do not open the power adapter casing. Only the manufacturer's qualified technician can access and service power adapters.
- For this specific appliance model, it is recommended to use the power supply that is shipped with the appliance or additional spare unit from Forecept.

Electrical safety precautions

Follow basic electrical safety precautions to protect yourself from harm and the appliance from damage.

- Know the locations of the power on/off button and the emergency turn-off switch, disconnection switch, or electrical outlet for the room. If an electrical accident occurs, you can quickly turn off power to the system.
- When working with high-voltage components, do not work alone.
- When working with electrical equipment that is turned on, use only one hand. This is to avoid making a complete circuit, which causes an electric shock. Use extreme caution when using metal tools, which can easily damage any electrical components or circuit boards the tools come into contact with.
- Do not use mats designed to decrease electrostatic discharge as protection from electric shock. Instead, use rubber mats that have been designed as electrical insulators.
- If the power supply cable includes a grounding plug, the plug must be plugged into a grounded electrical outlet.
- Use only the power cable or cables supplied with the appliance.



Note

Standby power is supplied to the appliance even when the appliance is turned off.

AC power supply safety precautions

The appliance power inlet is the disconnect device on the appliance.

Install the appliance

There are several tasks that must be completed before the appliance is installed.

These tasks and the installation of the appliance might be done by the same person or by different persons:

- The Security Management Center (SMC) administrator is responsible for the tasks that are needed before the appliance is installed.
- The on-site installer is responsible for installing the appliance.

For more information, see the *Forcepoint Next Generation Firewall Installation Guide*.

To prepare for the appliance installation, the SMC administrator must do the following:

- 1) If the SMC has not yet been installed, install the SMC.



Important

Do not install the SMC on the NGFW appliance.

The SMC can manage many NGFW appliances.

- 2) In the Management Client component of the SMC, create and configure the NGFW Engine element that represents the appliance.
- 3) In the Management Client component of the SMC, save the initial configuration.
The SMC administrator must either:
 - Upload the initial configuration to the Installation Server for plug-and-play configuration of the appliance.



Note

There are additional requirements for plug-and play configuration. See Knowledge Base article [9662](#).

- Give the on-site installer a USB drive that contains an initial configuration file for each appliance.

The on-site installer must do the following:

- 1) Inspect the appliance, delivery box, and all components included in the shipment.



Important

Do not use damaged appliances or components.

- 2) Connect all necessary power, network cables and other components, and then press the power button to turn on the appliance.

If the plug-and-play configuration method is not used, the on-site installer must insert the USB drive that contains the initial configuration files to configure the NGFW Engine software to an USB port before the appliance is turned on.

By default, only one power supply is shipped with the appliance. However, an additional power supply can be ordered and connected for redundancy.

Power supply monitoring is automatically enabled when the appliance is powered on using two power adapters. When power supply monitoring is enabled and only one power supply is present, a warning is provided in SMC engine info status pane.

- 3) When you have finished installing the appliance, inform the SMC administrator so that the administrator can check the status of the appliance in the Management Client.

Mount the N352, or N355 appliance on a wall

You can optionally mount the N352/N355 appliance on a wall.



Important

There are vents on the sides of the appliance. Keep other objects at least 100mm (4 inches) away from the appliance to ensure good air flow. Do not stack appliances.

Mounting the appliance on a wall has the following requirements:

- You can mount the appliance in a horizontal orientation only with the connectors for the cables facing down.
- The distance between the holes that you drill for the appliance in the wall must be 200mm (7.9 inches).
- Depending on the wall material, you might need to insert nylon plugs into the mounting holes that you drill for the appliance. No nylon plugs are supplied with the appliance.
- Two flat undercut screws are required. No screws are supplied with the appliance. The diameter of the screw heads must be 5.5mm (7/32 inch) and the thickness of the screw heads must be 2mm (5/64 inch).

Select screws that are suitable for the wall material and long enough to provide a firm mounting point for the appliance. If you have attached the four provided rubber feet to the bottom of the appliance, make sure that the screws are long enough to provide a firm mounting point for the appliance with the feet attached.

Make sure that the heads of the screws fit into the mounting holes on the bottom of the appliance before you drill the mounting holes in the wall.

Steps

- 1) Drill two holes 200mm (7.9 inches) apart in the wall in a horizontal orientation. Make sure that you leave enough clearance around the appliance.
- 2) If required, insert nylon plugs into the holes.
- 3) Insert the two screws into the holes and tighten the screws. Make sure that the screws are protruding from the wall to provide a firm mounting point for the appliance.
- 4) Align the mounting holes on the appliance with the screws, then place the appliance on the screws so that the cables are below the appliance. After the appliance is mounted on the wall and you have connected the cables, do not pull on the cables.



CAUTION

If you need to disconnect any cables after the appliance is mounted on the wall, hold the appliance in place while you disconnect the cables.

Rack-Mount the N352, or N355 appliance

The rack-mounting procedure varies depending on the type of rack unit. If needed, see the documentation for your rack unit.

Instead of rack-mounting the appliance, you can also place the appliance on a flat surface, such as a desk or shelf.

How to determine the placement of each component in the rack:

- Install the heaviest components on the bottom of the rack first. Install components from the bottom to the top.
- The appliance must be connected to a grounded power outlet.
- Use a UPS to protect the appliance from power surges and voltage spikes, and to keep your system operating if there is a power failure.
- To maintain proper cooling, always keep the front door of the rack and all panels and components on the appliances closed when not servicing.

Install the appliance in a rack

Use the rack-mounting brackets to secure the appliance in the rack.

Before you begin

The brackets and screws are not included by default. You can order them separately.

Use the rack-mounting brackets to secure the appliance in the rack.

Steps

- 1) Locate the brackets for the rack installation.



Note

The bracket delivery includes two rack-mounting brackets.

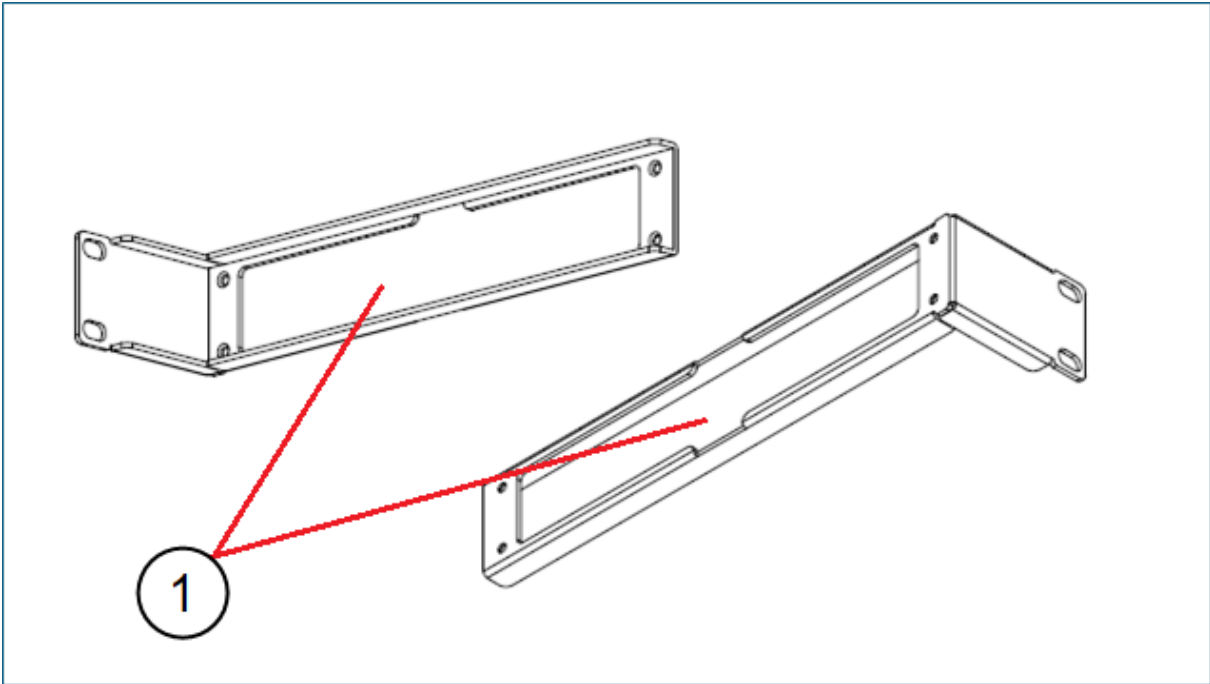

1 Rack-mounting brackets.

- 2) Unscrew the 4 screws from the left panel and the right panel of the appliance.



CAUTION

Do not reuse these screws for attaching the brackets. The screws are not long enough to properly attach the brackets.

- 3) Attach the brackets to the left and right panel of the appliance with 4 screws through the holes in each bracket.



Note

- The screws are included in the bracket kit.
- The rack-mounting bracket face that has two screw holes, must be aligned only with the back panel or front panel of the appliance.

- 4) Attach the bracket to the rack with two screws through the holes in the front of the appliance, and with two screws through the holes in the back of the appliance.

Connect the cables

Connect the network and power cables.

Use at least CAT5e-rated cables for gigabit networks.

Network interfaces at both ends of each cable must have identical speed and duplex settings. These settings include the automatic negotiation setting. If one end of the cable uses autonegotiation, the other end must also use autonegotiation. Gigabit standards require interfaces to use autonegotiation. Fixed settings are not allowed at gigabit speeds.

Connect the SFP+ transceivers

You must install appropriate SFP+ or SFP transceivers into the 8 to 11 interfaces before connecting them to 10Gbps or 1Gbps networks. For supported list of transceivers, see Knowledge Base article [37231](#) .

To install transceiver:

Steps

- 1) Attach the ESD wrist strap to your wrist and connect the attached grounding wire to the appliance grounding point.
- 2) Hold the sides of the transceiver and slide it into the port socket until clicks into place.
- 3) Disconnect the ESD grounding wire from the appliance.
- 4) Plug the appropriate cables into the transceiver and check the connection using the Ethernet Port Indicator LEDs.

Connect network cables

Ethernet ports are mapped to interface IDs during the initial configuration. Determine which Ethernet ports to use for connecting to your networks.

Steps

- 1) Connect network cables to the Ethernet ports.
If you use the plug-and-play configuration method for a single NGFW appliance, the appliance uses Ethernet port 0 to contact the Installation Server.
Web based NGFW Configuration Wizard runs on port labeled as LAN (port 2).
If the appliance is a node in an NGFW Engine cluster, connect the cable for the heartbeat connection between the nodes to interface labeled as HA (port 3).

Connect the power adapter



Note

We recommend using a UPS to ensure continuous operation and minimize the risk of damage to the appliance in case of sudden loss of power.

Steps

- 1) Attach a suitable power plug for your region to the 19V power adapter for the appliance. Standard power plugs for several regions are included with the delivery.
- 2) Connect the 19V power adapter for the appliance to the DC IN 1 power connector on the back of the appliance.
- 3) Plug the power adapter into a grounded, high-quality power strip that offers protection from electrical noise and power surges.

Port settings for plug-and-play configuration method

If you use the plug-and-play configuration method for a single NGFW appliance, the appliance uses Ethernet port 0 to contact the Installation Server.

To use the plug-and-play configuration method, the interface that corresponds to Ethernet port 0 in the initial configuration must have a dynamic IPv4 address.

Restoring appliance settings

You can use one of the following methods to restore the appliance settings to the factory default settings:

- If the appliance is connected to the management, use the `Reset to Factory Settings` command from the management client in SMC to initiate restoring of appliance settings.
- To initiate and complete the reset without using appliance console, connect to the appliance using SSH, and then use the CLI command `sg-clear-all --fast` to restore the factory default settings on the NGFW Engine.
- From local console boot menu, select **System restore options** to initiate restoring of appliance settings.
- Press and hold the reset button for few seconds to initiate restoring of appliance settings. For this method to work, appliance must have been powered on and running at least for two minutes. Reset button is shown right next to the Power button and for example can be pressed with a small pen tip. The system restore is ready when the appliance is switched to standby powered state ("power off"), which is indicated by red colored power LEDs. If serial console is in use, the following messages: "Factory default settings restored" and then "reboot: Power down" in console indicate that the system restore is ready.

**Note**

Restoring appliance settings does not impact the current software version. This will remain as the latest installed version.

Turn off the appliance

Most Forcepoint NGFW appliance hardware components are not hot-swappable.

You can turn off the appliance using either of the following ways:

- Using Power button
- Using Management Client
- From the NGFW Engine command line

Turn off the appliance using the power button

Power button includes the functions:

- Short press of the power button initiates software interfaces driven graceful power off. This is the recommended way to turn the power off using power button.
- Long press of the power button (over 2 seconds) initiates forceful power off. This option is used only if the appliance does not respond to graceful power off in 30 seconds.

Turn off the appliance using the Management Client

**Tip**

The SMC administrator can also turn off the appliance remotely using the Management Client. For more information, see the *Forcepoint Next Generation Firewall Product Guide*.

Turn off the appliance from the NGFW Engine command line

Steps

- 1) Connect to the NGFW Engine command line.

Depending on the appliance type, use one of the following options:

- Connect a computer running a terminal emulator program to the appliance console port, then press **Enter**.
- Connect using SSH.

**Note**

SSH access is not enabled by default.

- 2) Enter the logon credentials.

The user name is `root` and the password is the one you set for the appliance.

- 3) Enter the following command:

```
halt
```

- 4) Wait until the power indicator light turns red or is unlit, then unplug all power cables from the appliance.

